



US 20180030978A1

(19) **United States**

(12) **Patent Application Publication**
McCarthy

(10) **Pub. No.: US 2018/0030978 A1**

(43) **Pub. Date: Feb. 1, 2018**

(54) **GAS COMPRESSOR AND SYSTEM AND METHOD FOR GAS COMPRESSING**

E21B 41/00 (2006.01)

F04B 35/00 (2006.01)

(71) Applicant: **I-JACK TECHNOLOGIES INCORPORATED**, Moosomin (CA)

(52) **U.S. Cl.**

CPC *F04B 49/002* (2013.01); *F04B 35/00* (2013.01); *F04B 47/04* (2013.01); *E21B 41/00* (2013.01); *E21B 43/126* (2013.01)

(72) Inventor: **Dan McCarthy**, Moosomin (CA)

(21) Appl. No.: **15/659,229**

(57)

ABSTRACT

(22) Filed: **Jul. 25, 2017**

Related U.S. Application Data

(60) Provisional application No. 62/421,558, filed on Nov. 14, 2016, provisional application No. 62/513,182, filed on May 31, 2017.

Publication Classification

(51) **Int. Cl.**

F04B 49/00 (2006.01)

F04B 47/04 (2006.01)

Methods and systems are provided to adaptively control a hydraulic fluid supply to supply a driving fluid for applying a driving force on a piston in a gas compressor, the driving force being cyclically reversed between a first direction and a second direction to cause the piston to reciprocate in strokes. During a first stroke of the piston, a speed of the piston, a temperature of the driving fluid, and a load pressure applied to the piston is monitored. Reversal of the driving force after the first stroke is controlled based on the speed, load pressure, and temperature.

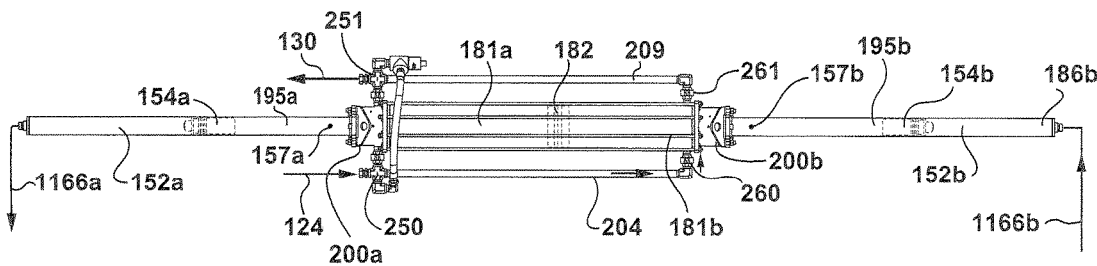
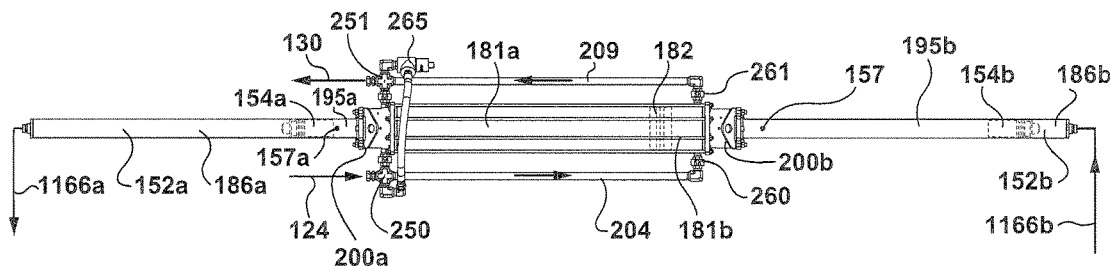

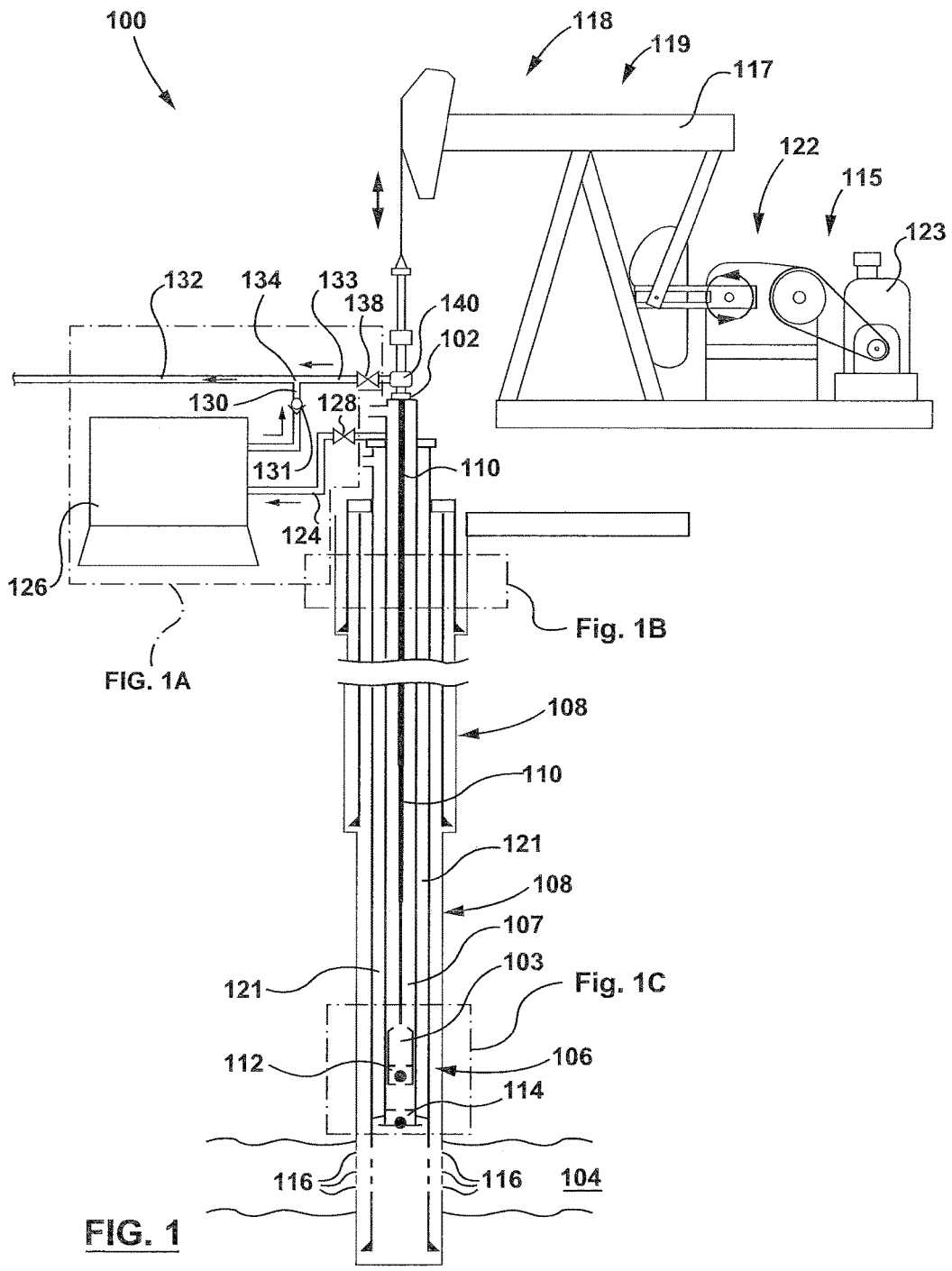

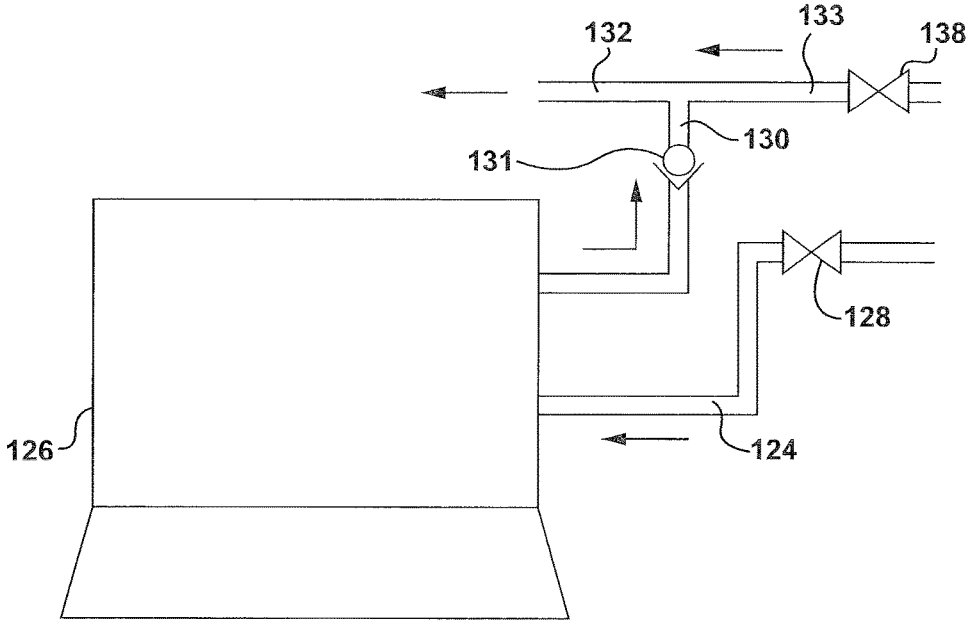

FIG. 1A

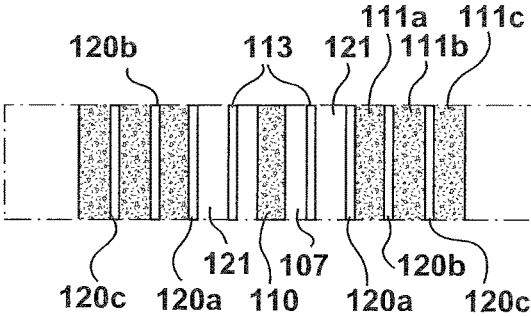

FIG. 1B

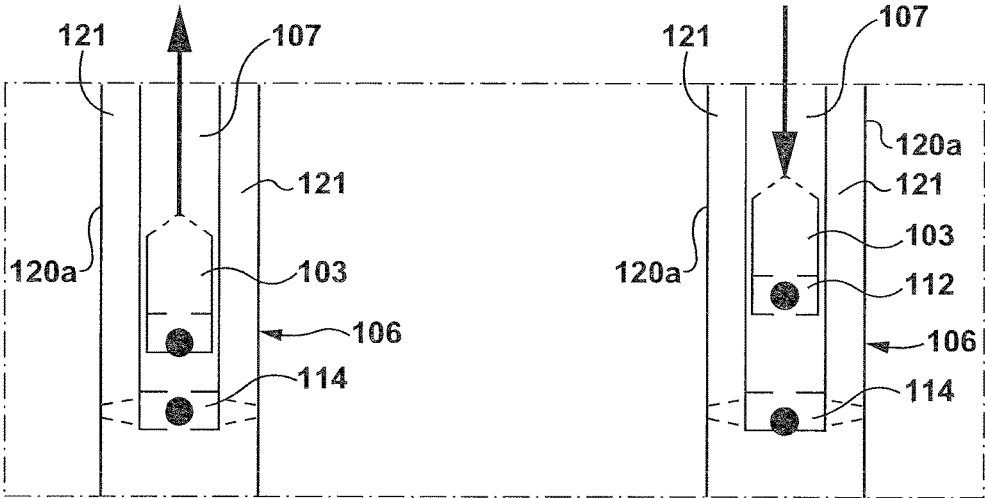

FIG. 1C

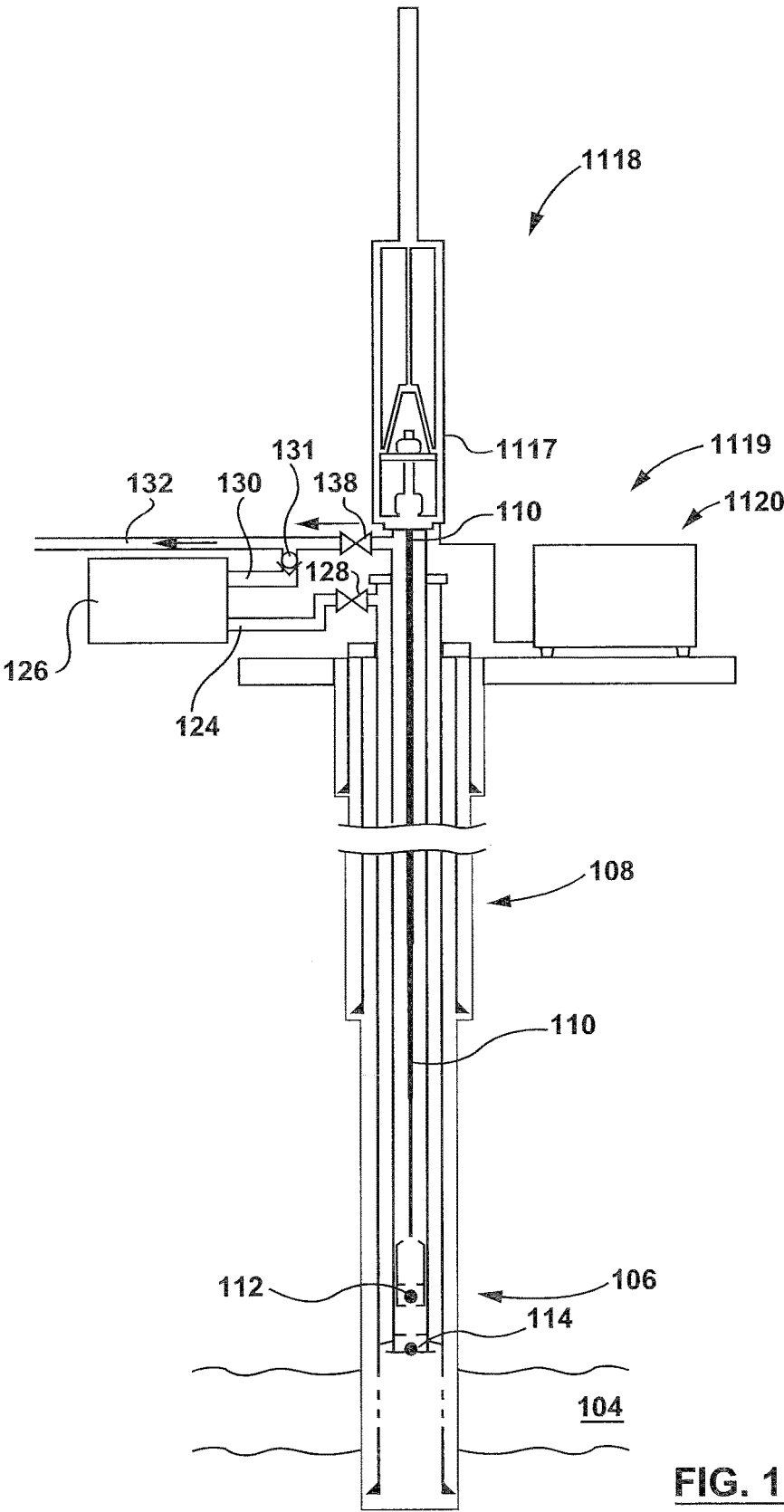

FIG. 1D

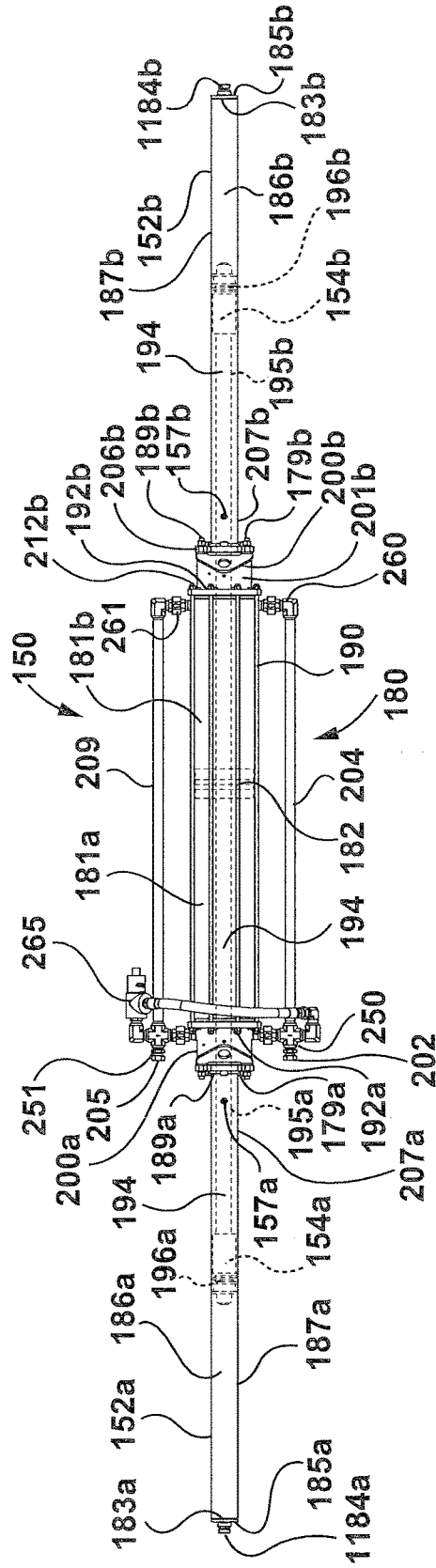

FIG. 2

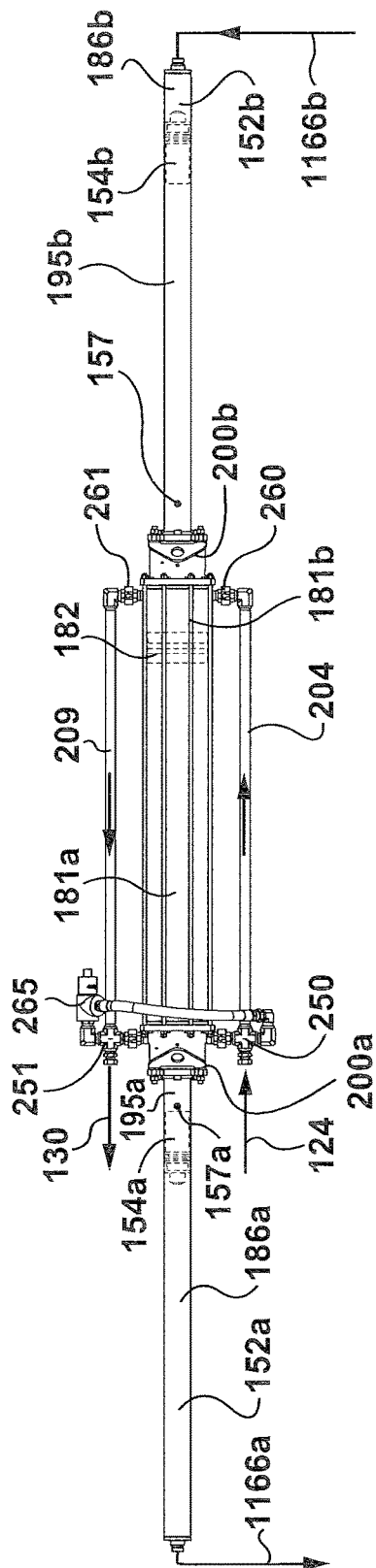

FIG. 3 (i)

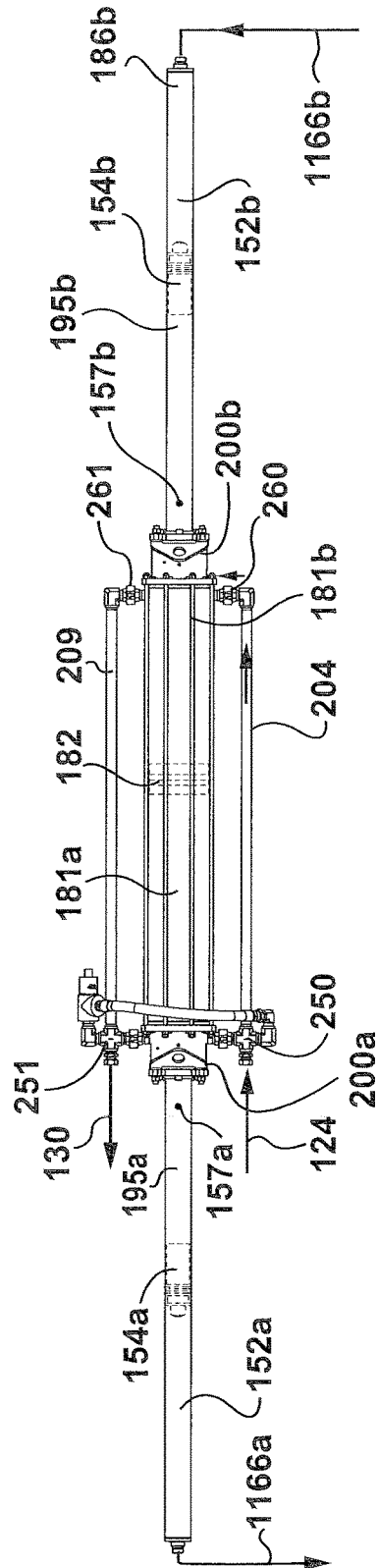

FIG. 3 (ii)

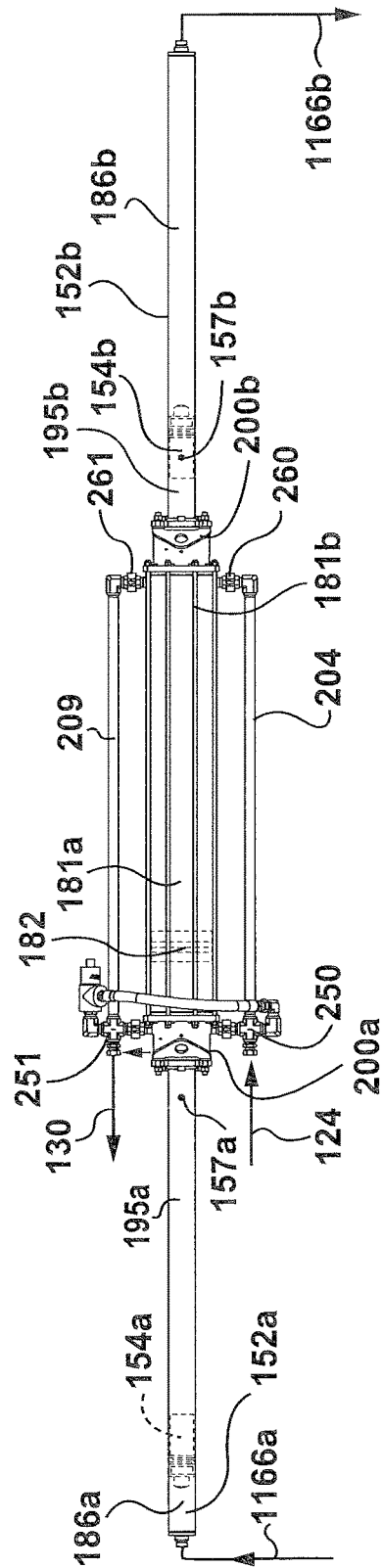

FIG. 3 (iii)

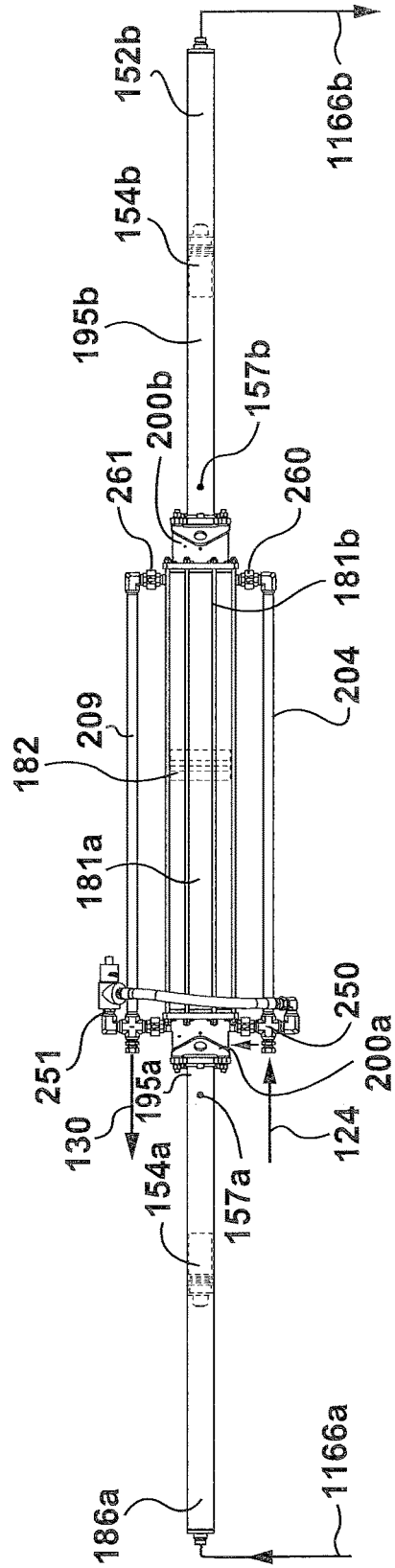

FIG. 3 (iv)

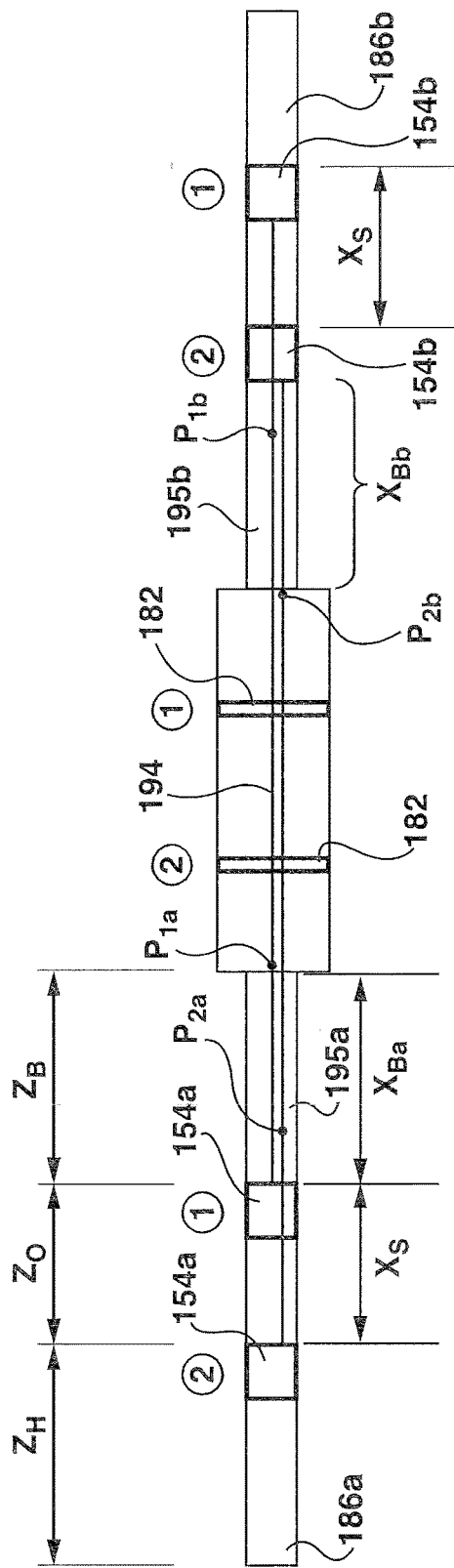

FIG. 4

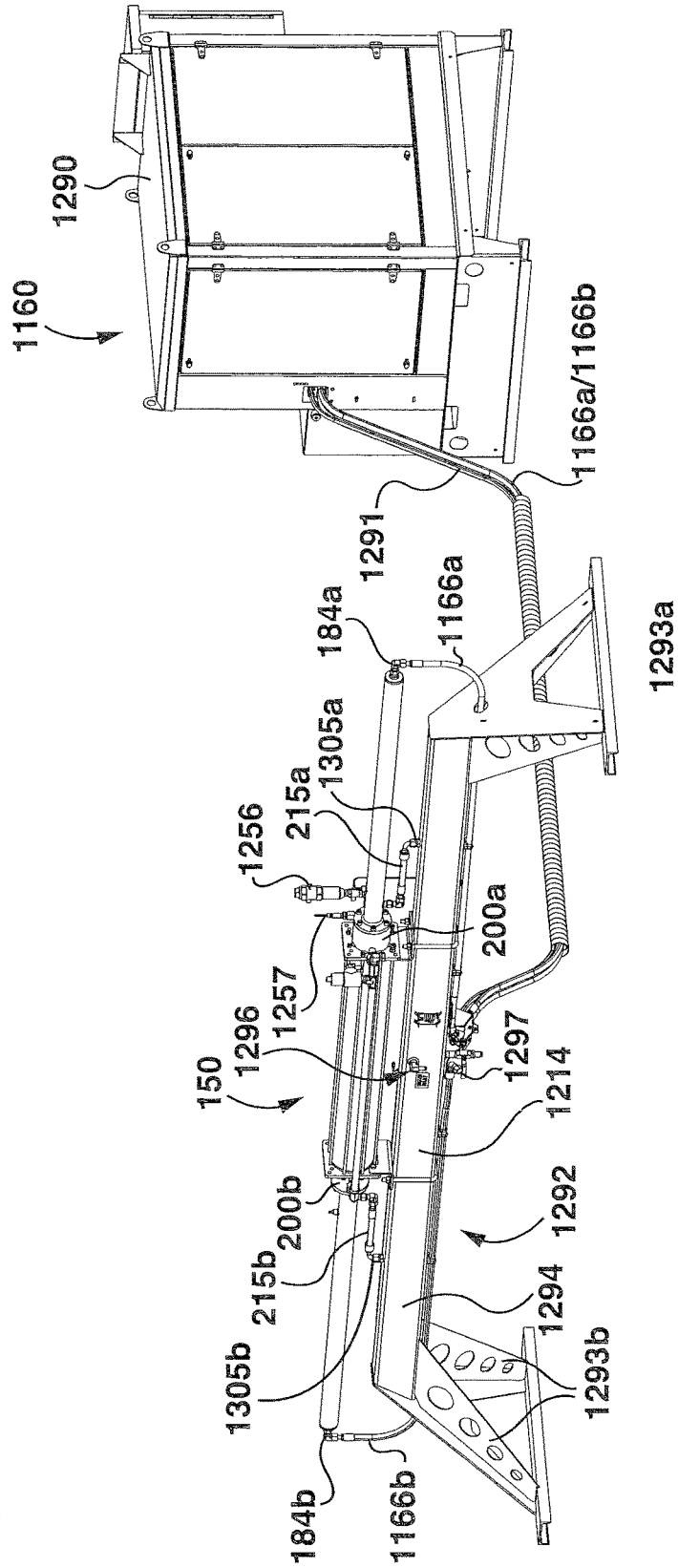

FIG. 5

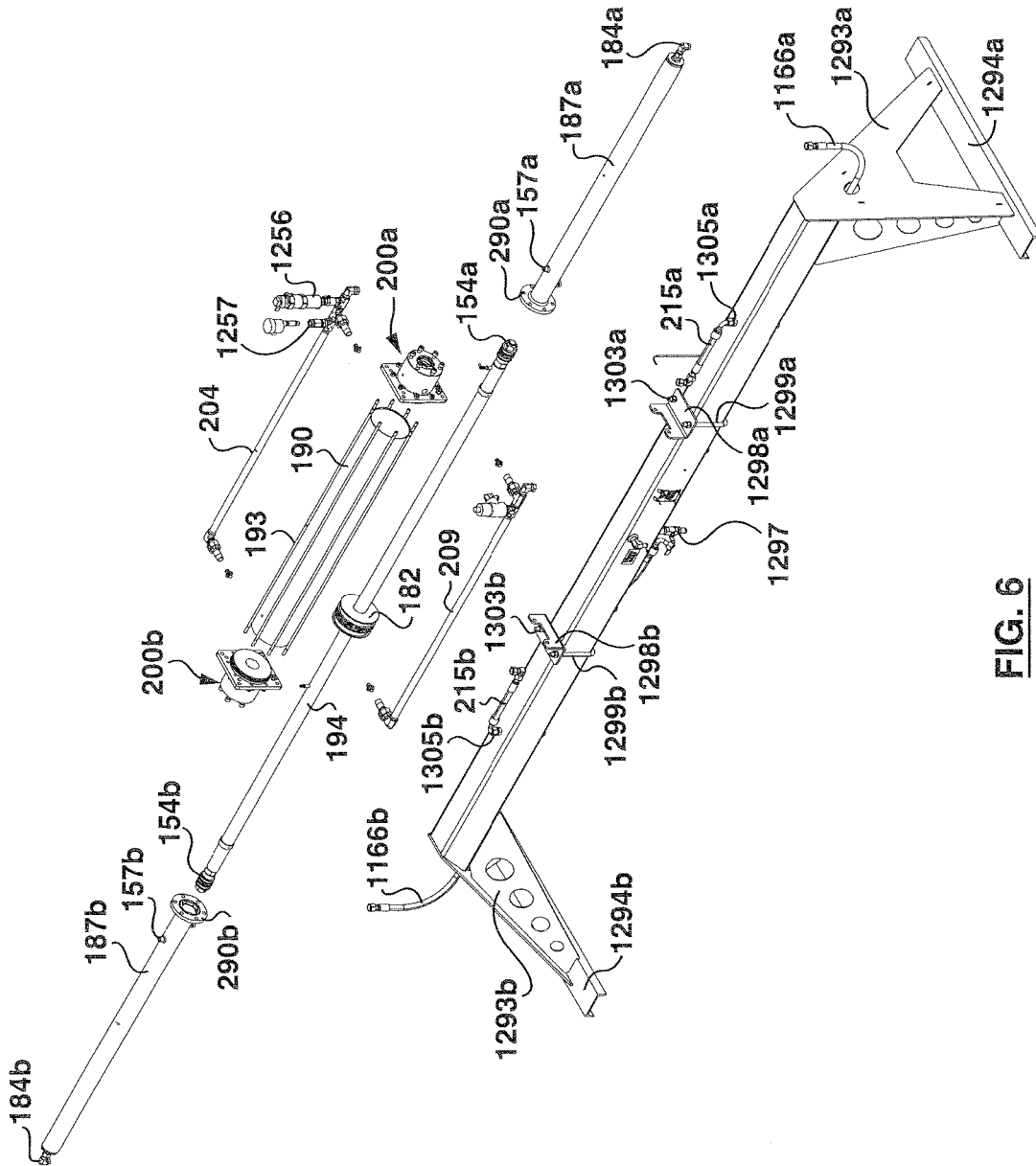

FIG. 6

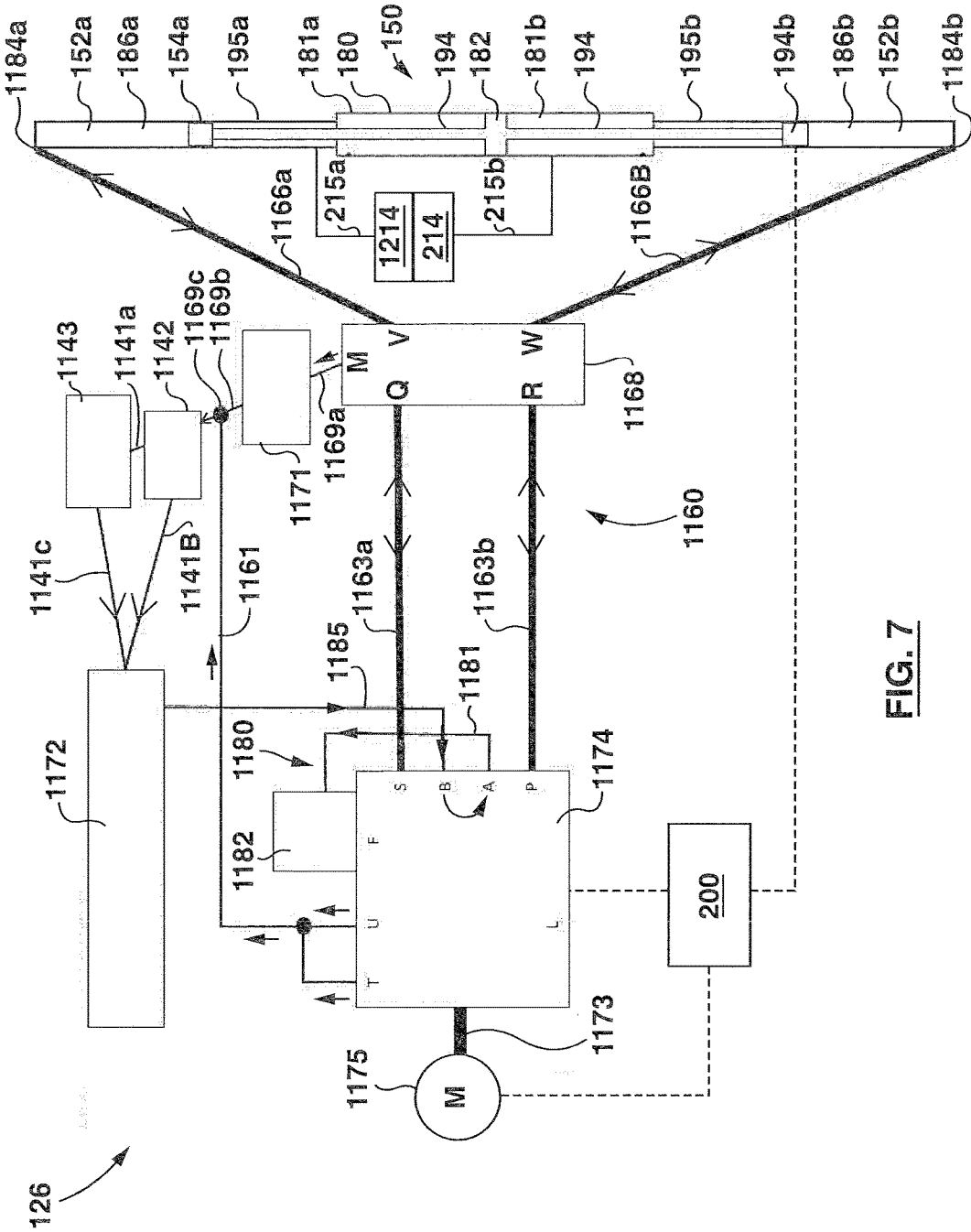

FIG. 7

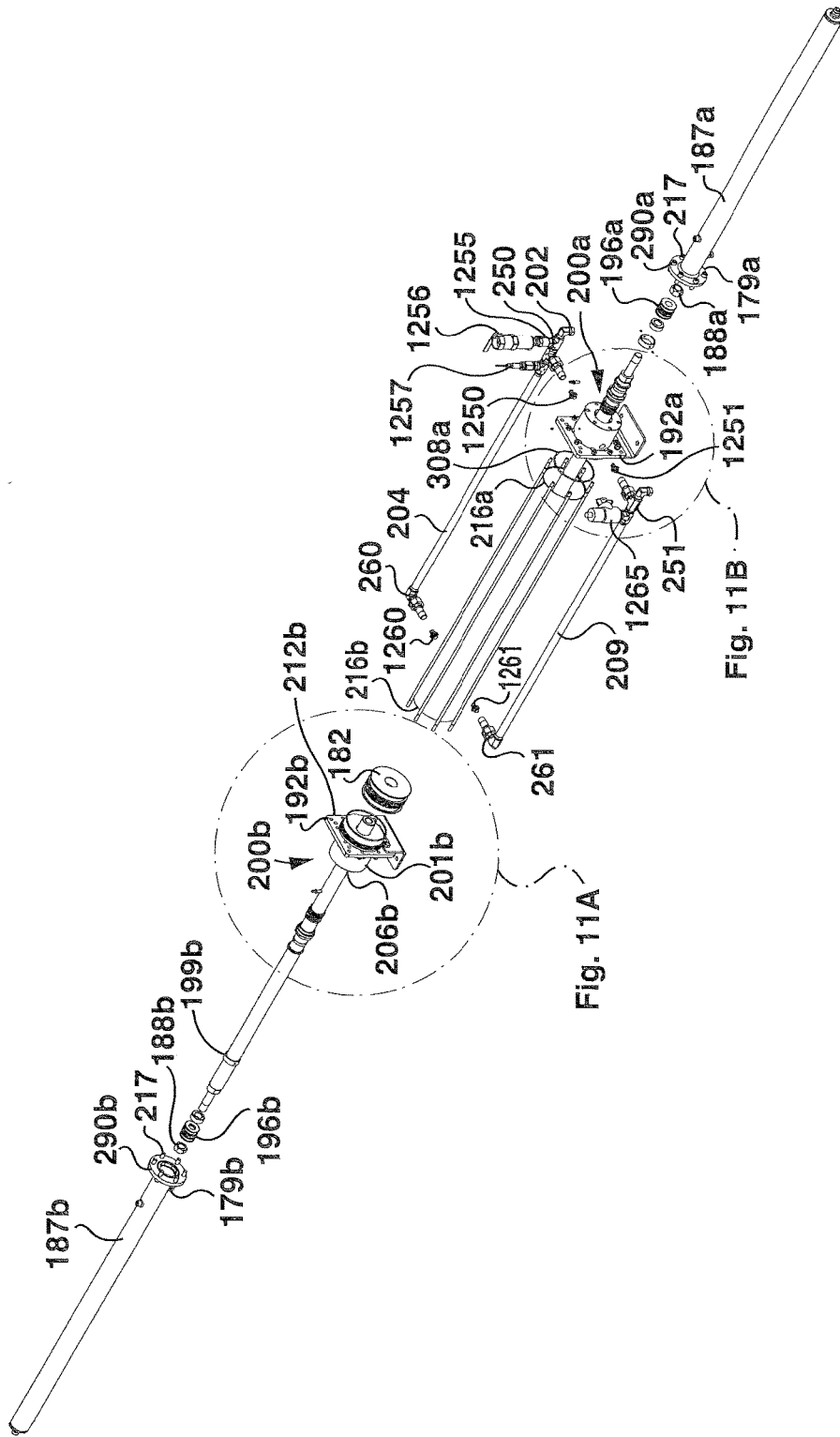

FIG. 8

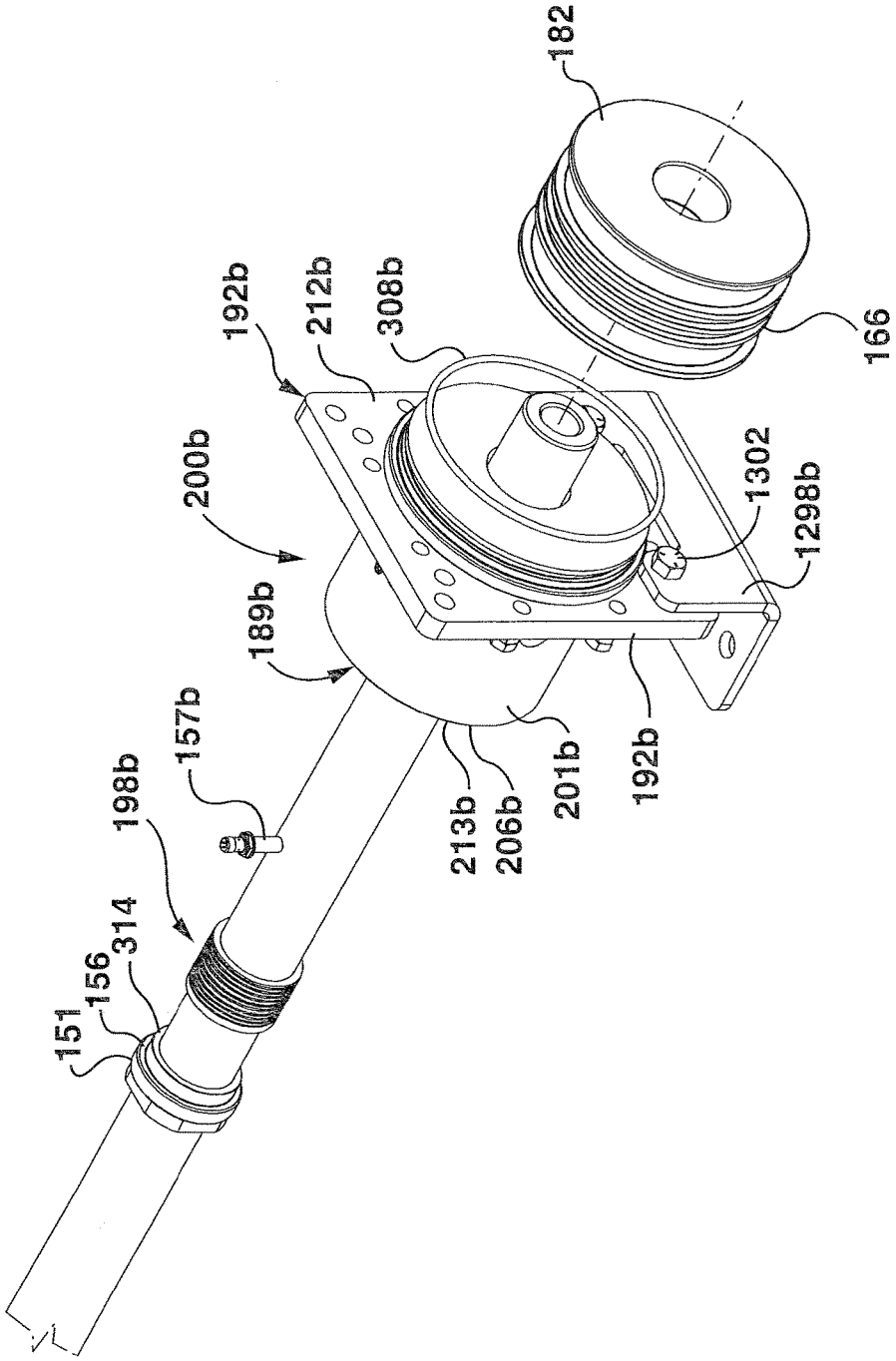

FIG. 8A

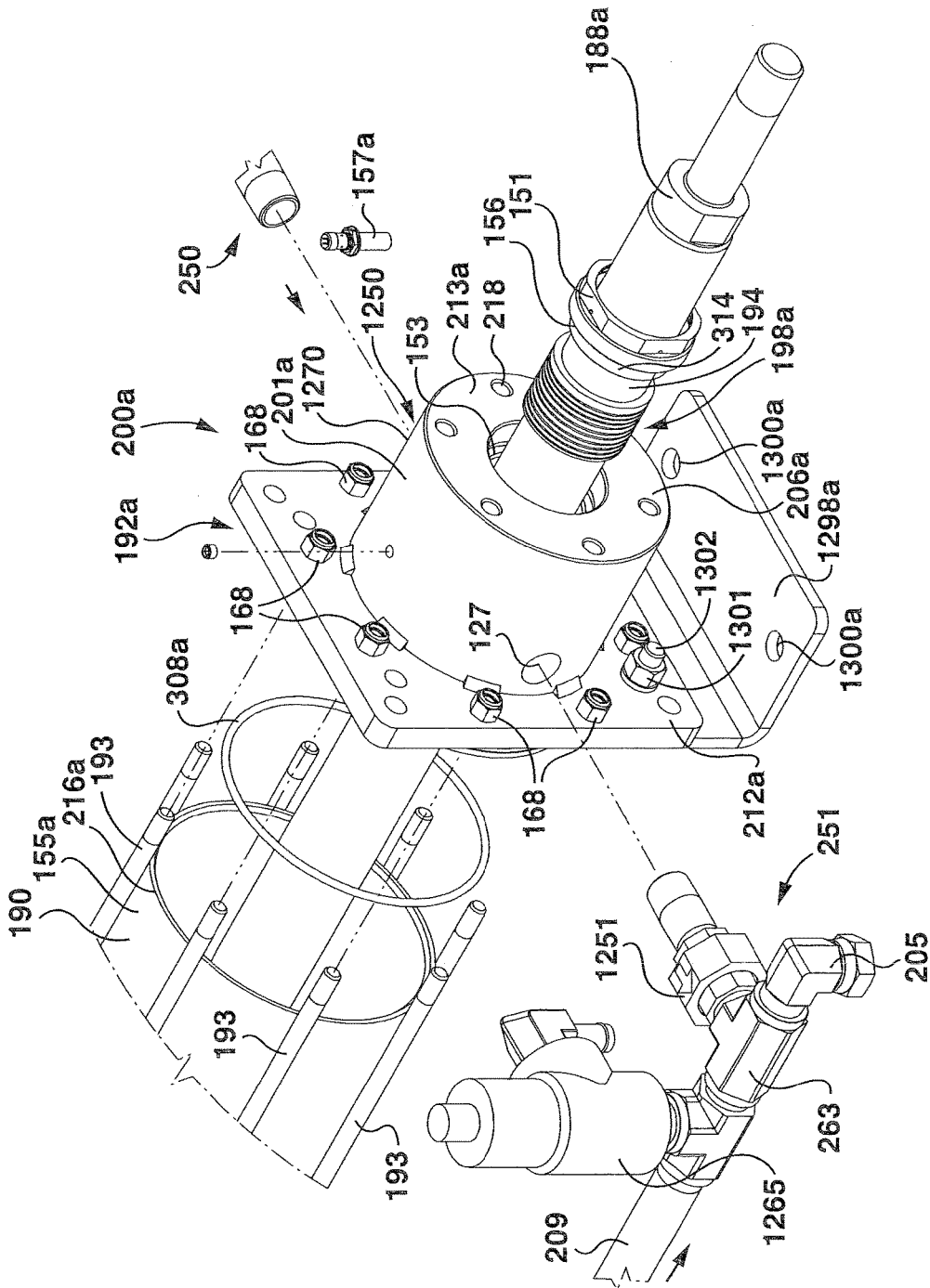

FIG. 8B

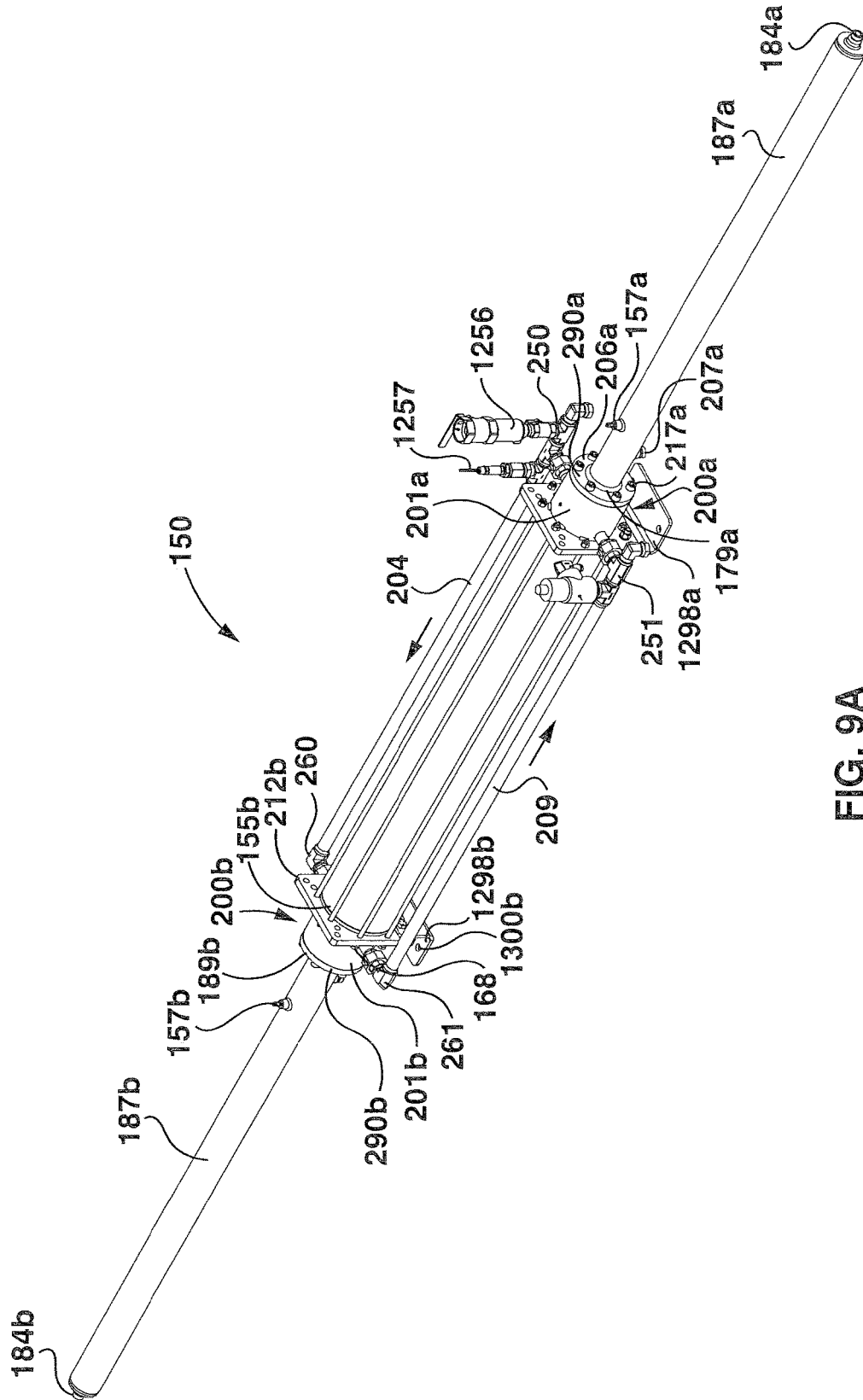

FIG. 9A

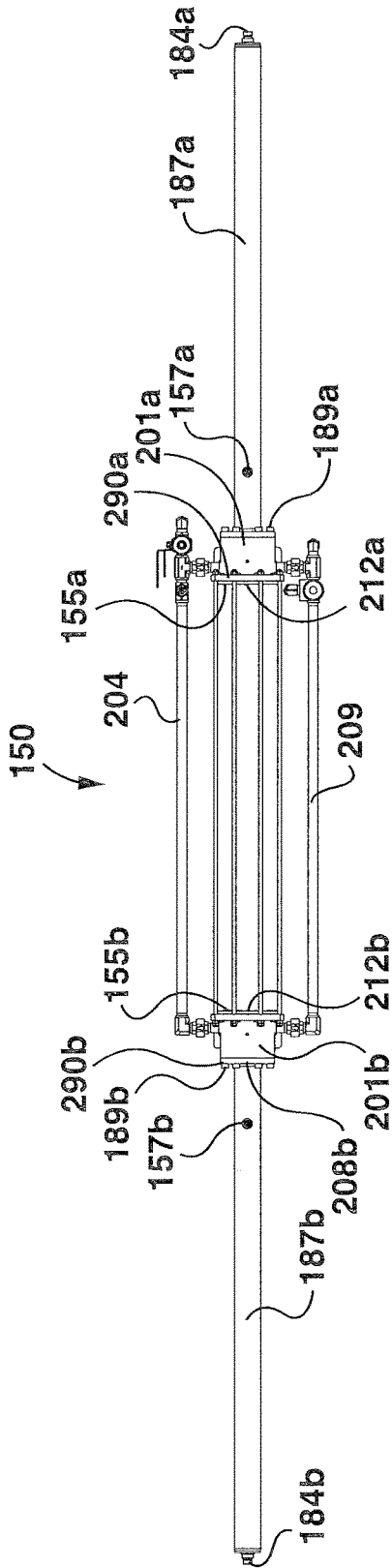

FIG. 9B

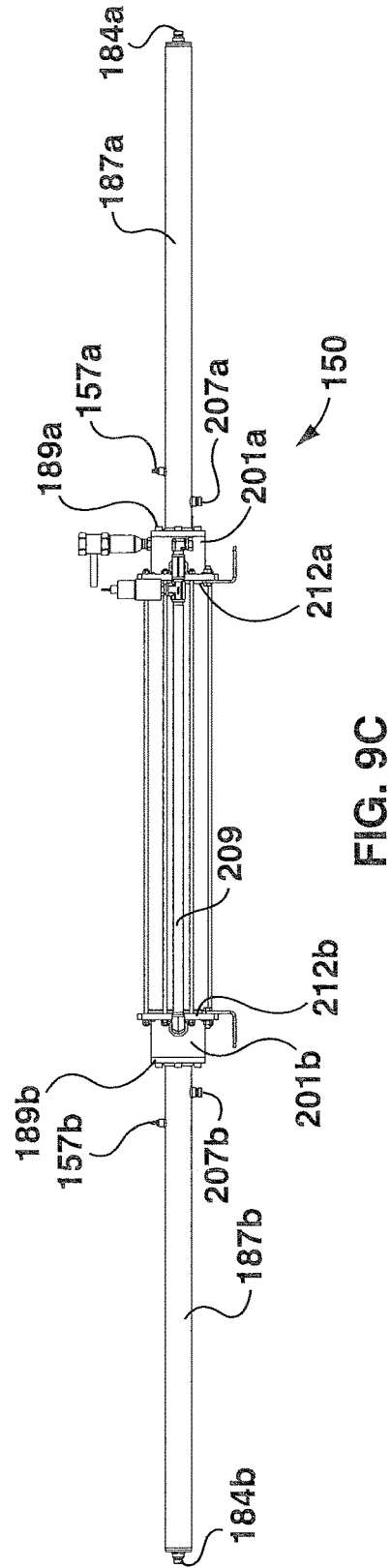

FIG. 9C

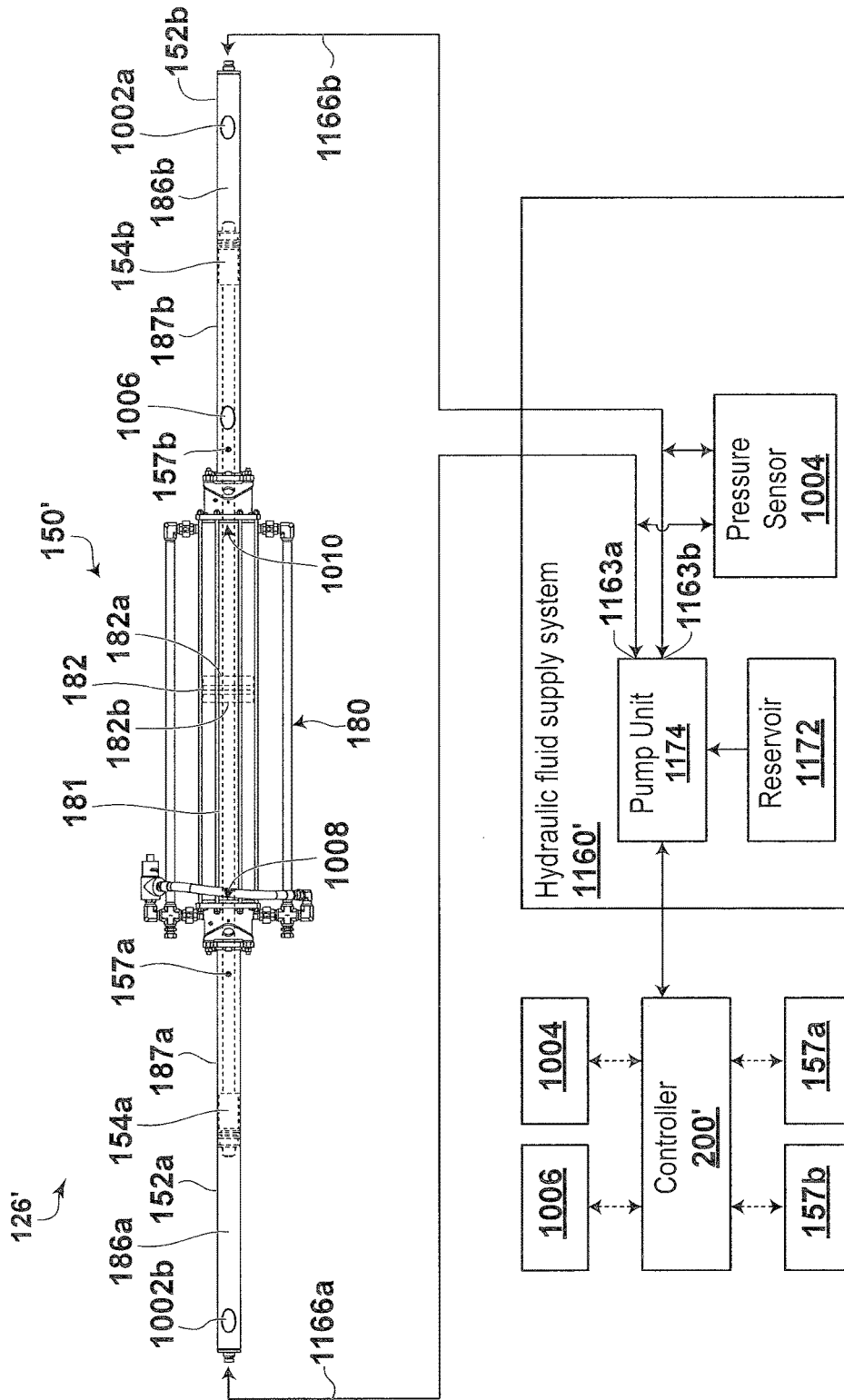

FIG. 10A

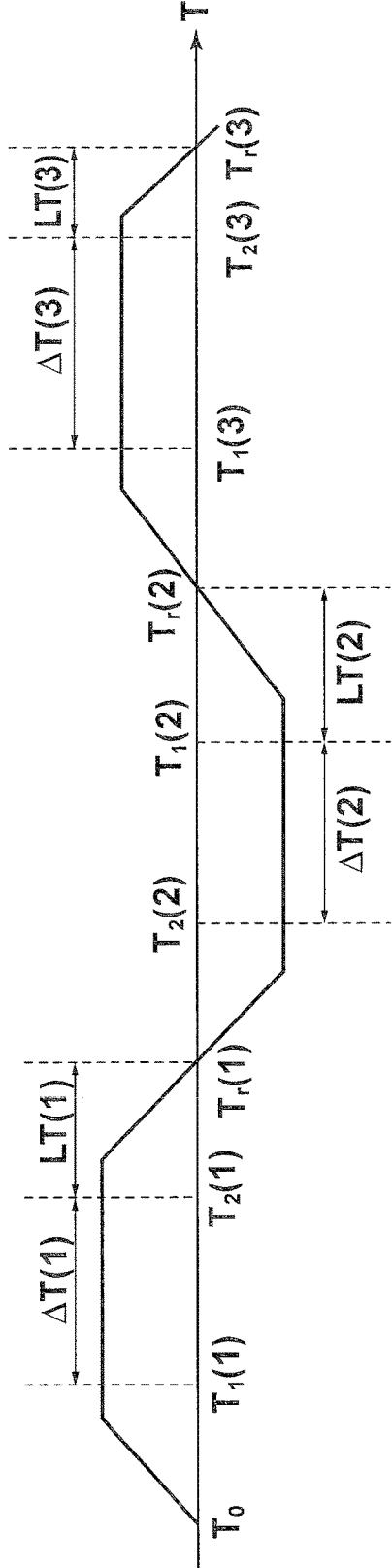
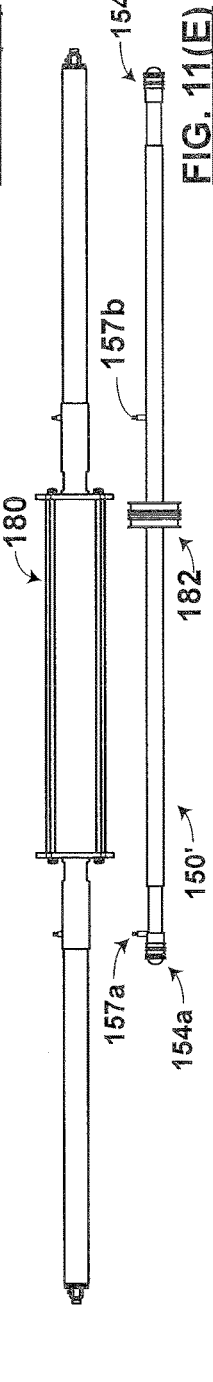
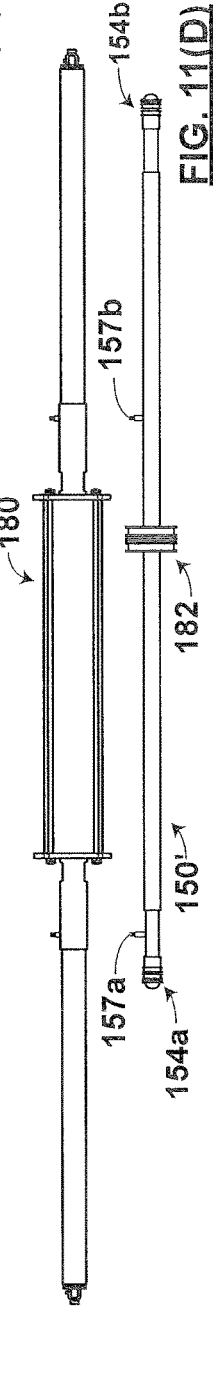
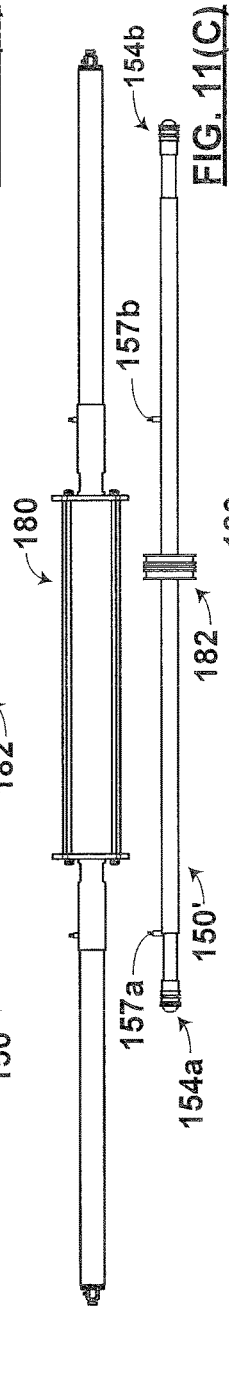
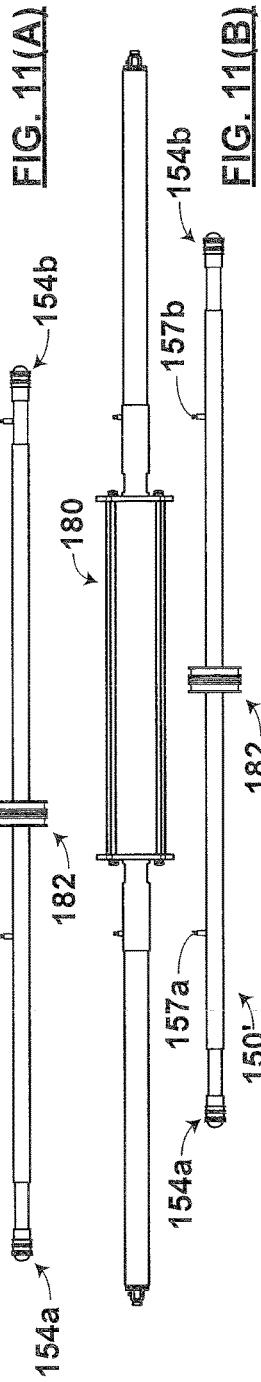
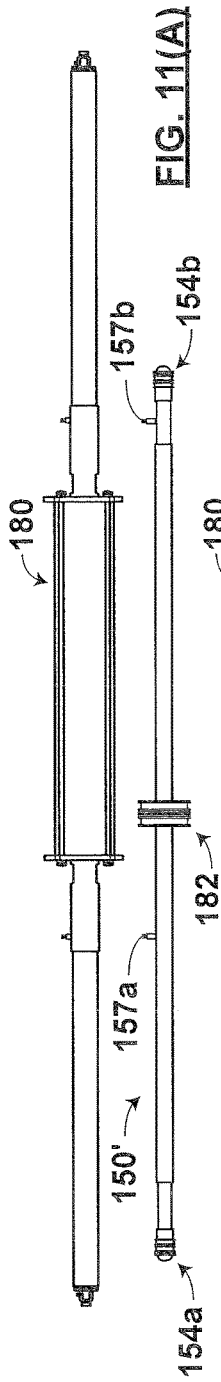

FIG. 10B



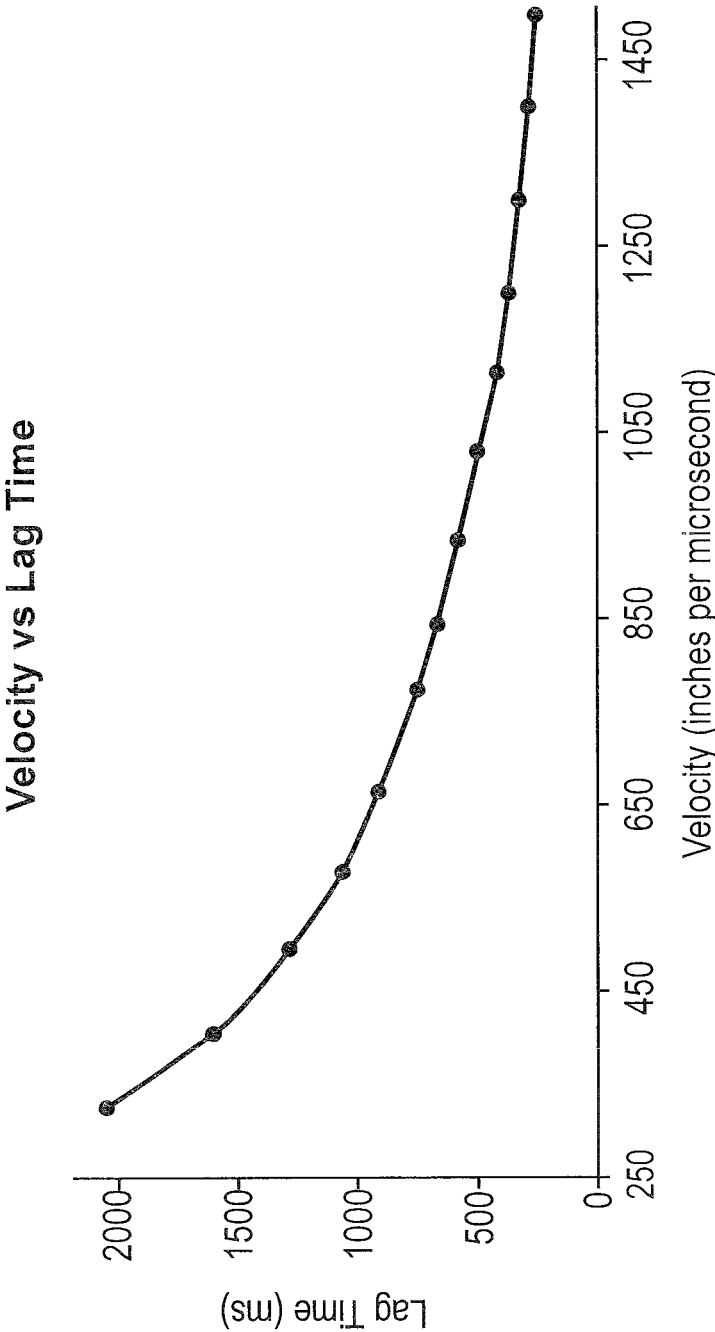

FIG. 12

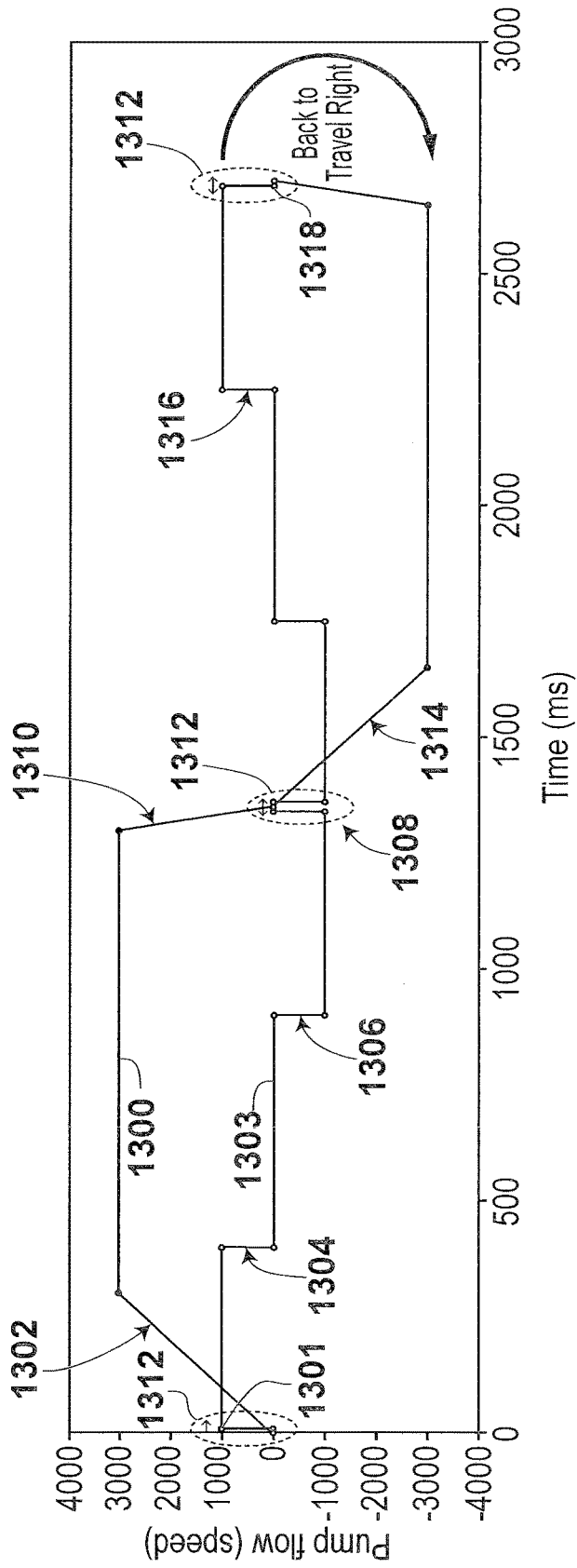

FIG. 13

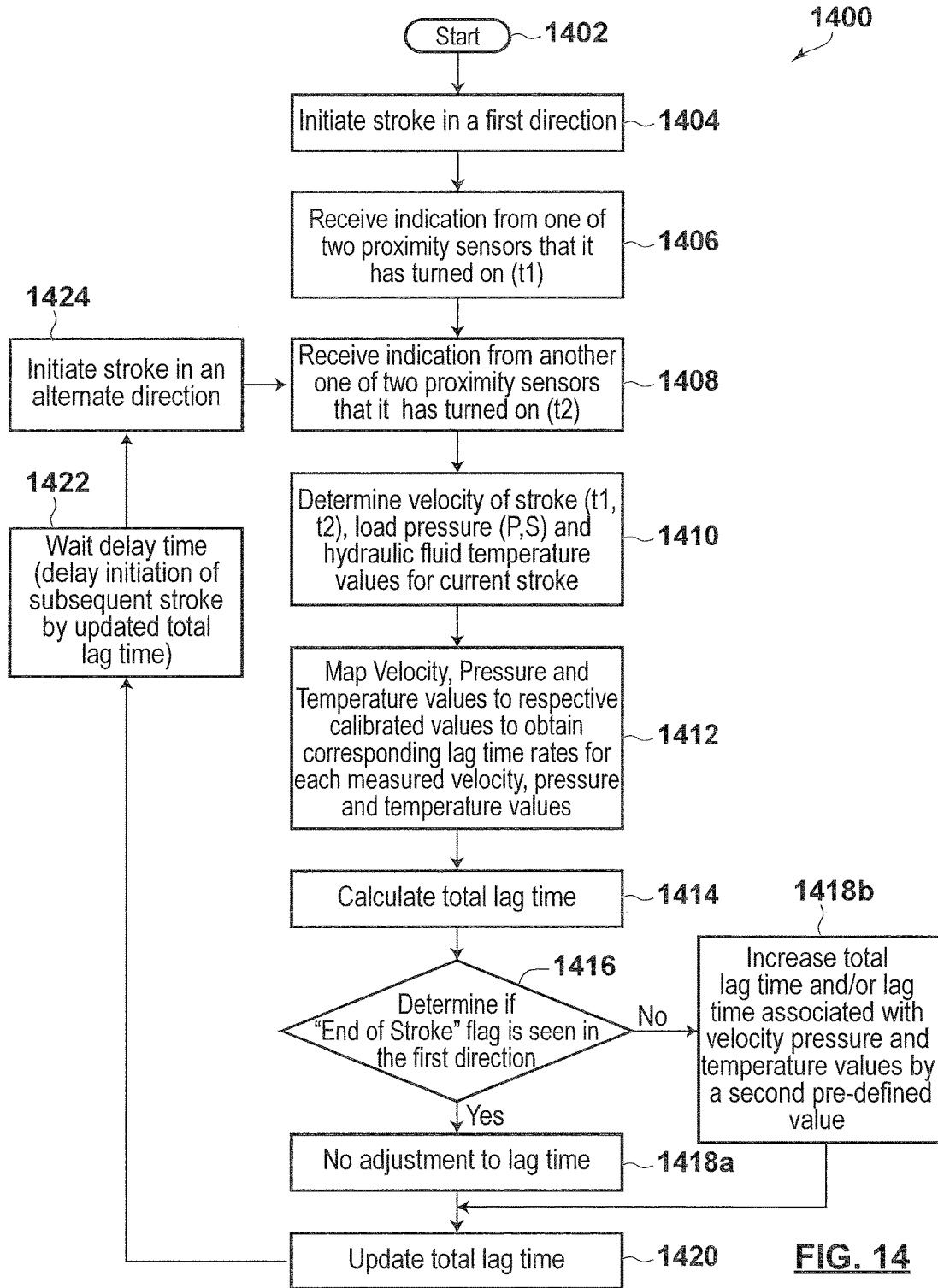
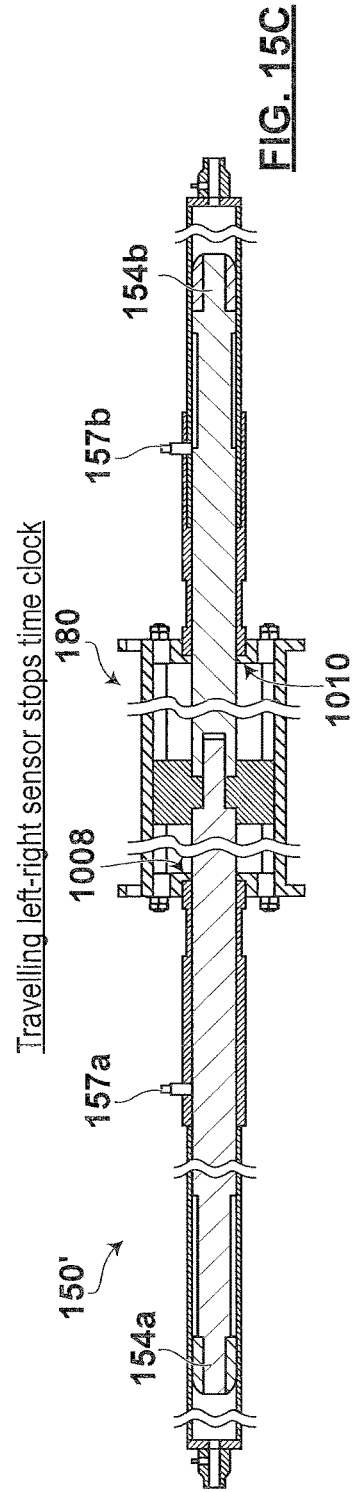
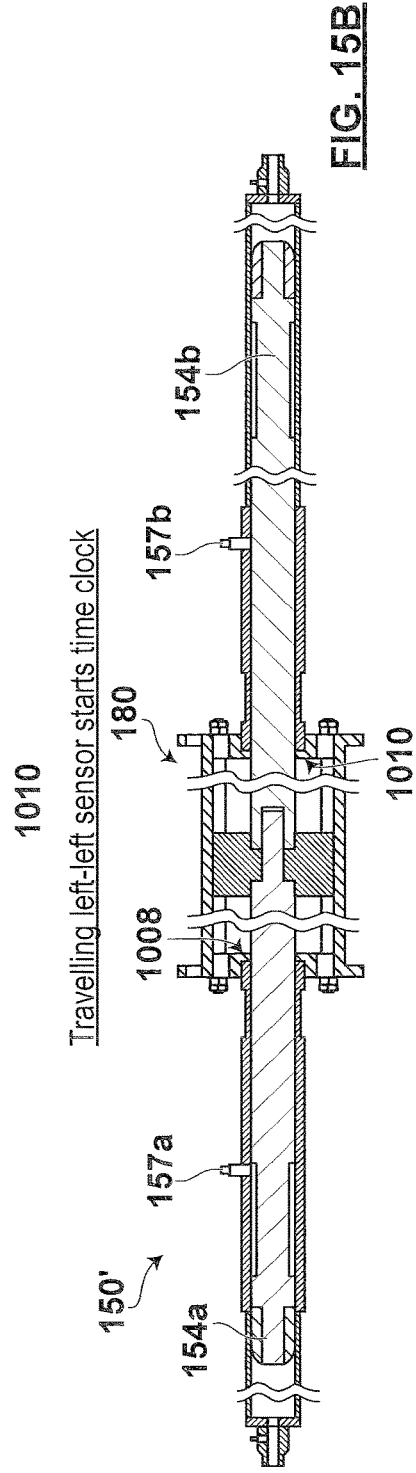
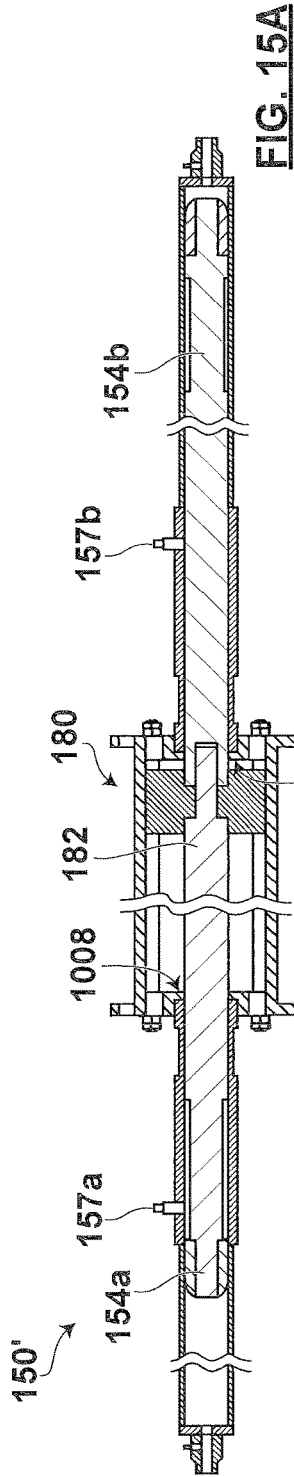

FIG. 14



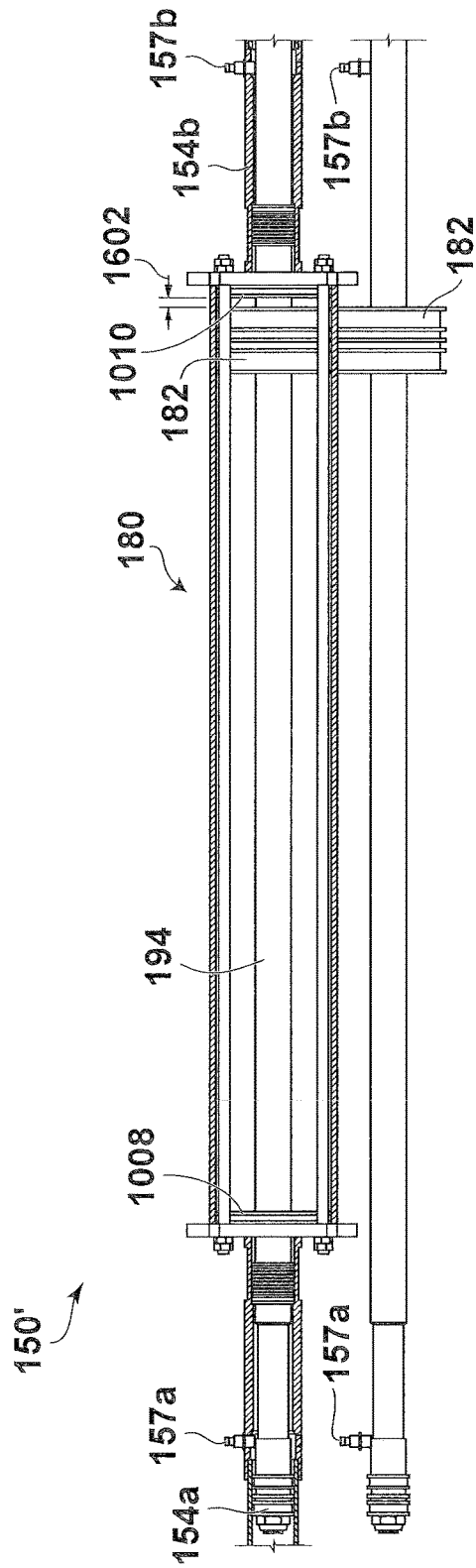

FIG. 16

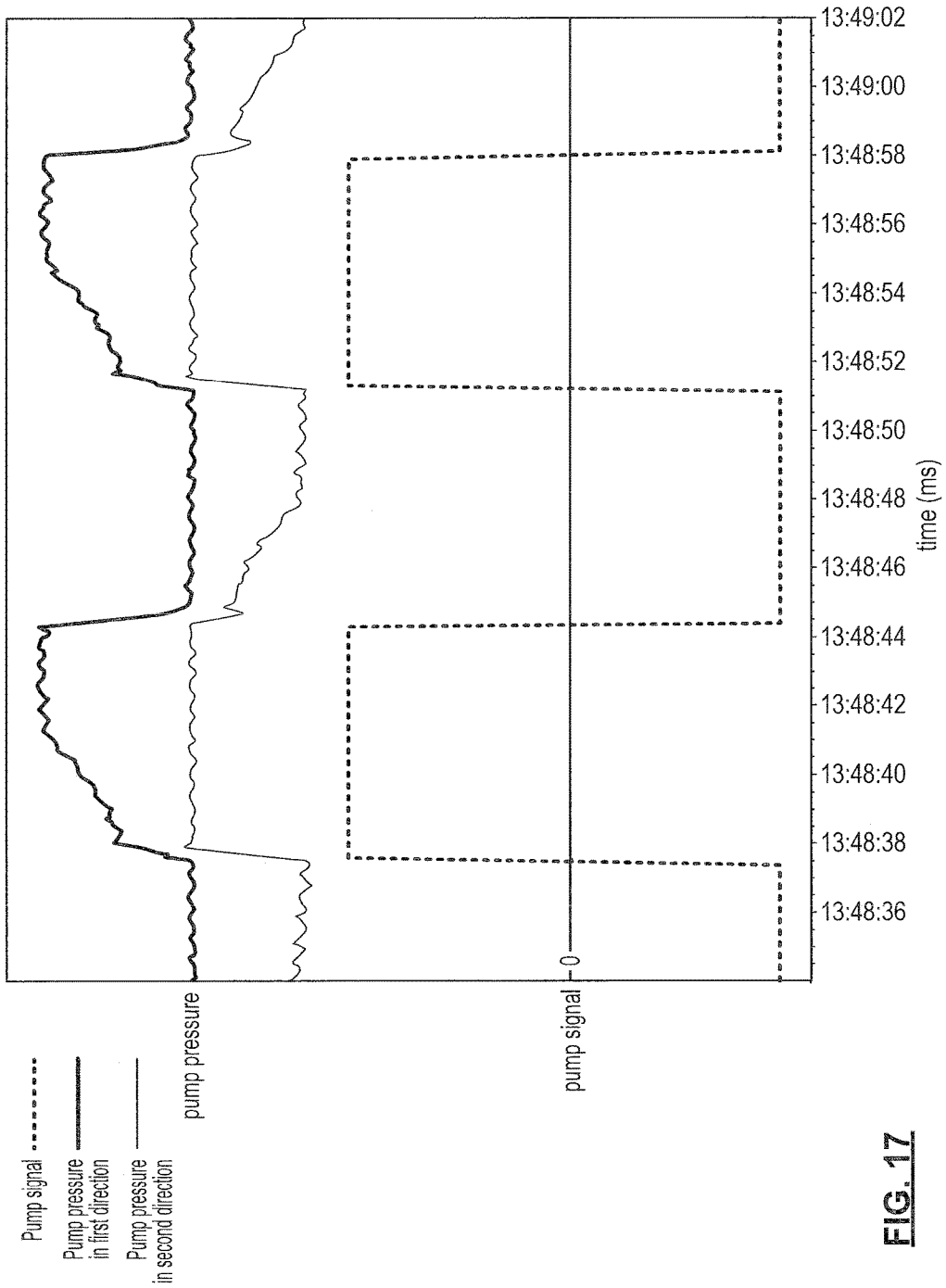

FIG. 17

GAS COMPRESSOR AND SYSTEM AND METHOD FOR GAS COMPRESSING

CROSS-REFERENCE TO RELATED APPLICATION

[0001] This application claims the benefit of, and priority from, U.S. Provisional Patent Application No. 62/513,182, filed May 31, 2017, and U.S. Provisional Patent Application No. 62/421,558, filed Nov. 14, 2016, the entire contents of each of which are incorporated herein by reference.

TECHNICAL FIELD

[0002] The present disclosure relates to systems and methods for gas compressing, and gas compressors driven by a driving fluid such as a hydraulic fluid, including hydraulic gas compressors driven by hydraulic fluid that are used in oil and gas field applications.

BACKGROUND

[0003] Various different types of gas compressors to compress a wide range of gases are known. Hydraulic gas compressors in particular are used in a number of different applications. One such category of, and application for, gas compressors is a gas compressor employed in connection with the operation of oil and gas producing well systems. When oil is extracted from a reservoir using a well and pumping system, it is common for natural gas, often in solution, to also be present within the reservoir. As oil flows out of the reservoir and into the well, a wellhead gas may be formed as it travels into the well and may collect within the well and/or travel within the casing of the well. The wellhead gas may be primarily natural gas and also includes impurities such as water, hydrogen sulphide, crude oil, and natural gas liquids (often referred to as condensate).

[0004] The presence of natural gas within the well can have negative impacts on the functioning of an oil and gas producing well system. It can for example create a back pressure on the reservoir at the bottom of the well shaft that inhibits or restricts the flow of oil to the well pump from the reservoir. Accordingly, it is often desirable to remove the natural gas from the well shaft to reduce the pressure at the bottom of the well shaft, particularly in the vicinity of the well pump. Natural gas that migrates into the casing of the well shaft may be drawn upwards—such as by venting to atmosphere or connecting the casing annulus to a pipe that allows for gas to flow out of the casing annulus. To further improve the flow of gas out of the casing annulus and reduce the pressure of the gas at the bottom of the well shaft, the natural gas flowing from the casing annulus may be compressed by a gas compressor and then may be utilized at the site of the well and/or transported for use elsewhere. The use of a gas compressor will further tend to create a lower pressure at the top of the well shaft compared to the bottom of the well shaft, assisting in the flow of natural gas upwards within the well bore and casing.

[0005] There are concerns in using hydraulic gas compressors in oil and gas field environments, relating to the potential contamination of the hydraulic fluid in the hydraulic cylinder of a gas compressor from components of the natural gas that is being compressed.

[0006] There are additional concerns in inefficient hydraulic gas compressor operation and increased costs associated with using such compressors.

[0007] Improved gas compressors and control systems and methods are desirable, including gas compressors employed in connection with oil and gas field operations including in connection with oil and gas producing wells.

SUMMARY

[0008] In an aspect of the disclosure, there is provided a method of adaptively controlling a hydraulic fluid supply to supply a driving fluid for applying a driving force on a piston in a hydraulic gas compressor, such as a double action hydraulic gas compressor. During operation, the driving force is cyclically reversed between a first direction and a second direction to cause the piston to reciprocate in strokes. During a stroke of the piston, a speed of the piston, a temperature of the driving fluid, and a load pressure applied to the piston are monitored. Reversal of the driving force after the stroke is controlled based on the speed, temperature, and load pressure.

[0009] In selected embodiments, the reversal timing may be controlled primarily based on the speed of the piston, but with other minor considerations, such as load pressure and driving fluid temperature. A pair of proximity sensors may be used to detect the piston speed and whether the piston reaches predefined end of stroke positions.

[0010] Conveniently, such control based on the monitored speed, temperature, and load pressure allows quick adjustment of the timing of reversing the driving force applied on the compressor piston in real-time to achieve both smooth transition between strokes and near maximum compression efficiency, under varying environment and operation conditions.

[0011] In an embodiment, the present disclosure relates to a method of adaptively controlling a hydraulic fluid supply to supply a driving fluid for applying a driving force on a piston in a gas compressor, the driving force being cyclically reversed between a first direction and a second direction to cause the piston to reciprocate in strokes, the method comprising monitoring, during a first stroke of the piston, a speed of the piston, a temperature of the driving fluid, and a load pressure applied to the piston; and controlling reversal of the driving force after the first stroke based on the speed, load pressure, and temperature.

[0012] In another embodiment, the present disclosure relates to a control system for adaptively controlling a hydraulic fluid supply to supply a driving fluid for applying a driving force on a piston in a gas compressor, the driving force being cyclically reversed between a first direction and a second direction to cause the piston to reciprocate in strokes. The system comprises first and second proximity sensors positioned and configured to respectively generate a first signal indicative of a first time (T1) when a first part of the piston is in proximity of the first proximity sensor, and a second signal indicative of a second time (T2) when a second part of the piston is in a proximity of the second proximity sensor, whereby the speed of the piston is calculable based on T1, T2 and a distance between the first and second proximity sensors; a temperature sensor positioned and configured to generate a signal indicative of a temperature of the driving fluid; and a controller configured to receive signals from the sensors and for controlling the hydraulic fluid supply to control reversal of the driving force based on the speed of the piston, the temperature of the driving fluid, and the load pressure applied to the piston during the first stroke.

[0013] In a further embodiment, the present disclosure relates to a gas compressor system that comprises a controller; a gas compressor that comprises a first driving fluid cylinder having a first driving fluid chamber adapted for containing a first driving fluid therein, and a first driving fluid piston movable within the first driving fluid chamber; a gas compression cylinder having a gas compression chamber comprising a first end and a second end, the gas compression chamber adapted for holding a gas therein and a gas piston reciprocally movable within the gas compression chamber between the first and the second end for compressing a gas; a second driving fluid cylinder having a second driving fluid chamber adapted for containing a second driving fluid therein, and a second driving fluid piston movable within the second driving fluid chamber; the first and second driving fluid cylinders located at each end of the gas compression cylinder and each of the first and second driving fluid pistons connected to the gas piston for axially driving the gas piston between the first and the second end; a first and a second proximity sensor respectively coupled to the first and second driving fluid cylinders, the first and second proximity sensors respectively operable to indicate a first and second time when a pre-defined portion of the first and the second driving fluid pistons is proximal to a respective one of the sensors and send the first and the second time to the controller in response thereto, the controller for determining a speed of movement of the gas piston within the gas compression chamber between the first and second end based on the first and second time; a temperature sensor coupled to one of the driving fluid cylinders and operable to detect a temperature of a respective one of the driving fluids and provide a temperature signal indicative of the temperature to the controller; a pressure sensor coupled to the driving fluid cylinders and operable to detect a pressure difference between the first and second driving fluids and provide a pressure signal indicative of the pressure difference to the controller; and the controller in communication with the temperature sensor, the pressure sensor and the first and second proximity sensors, the controller configured to control the flow of driving fluid into and out of each of the driving fluid chambers for causing a subsequent movement of the gas piston in an opposite direction between the second end and the first end in a second other stroke in response to the pressure signal, the temperature signal and the speed.

[0014] In another embodiment, the present disclosure relates to a gas compressor system that comprises a driving fluid cylinder having a driving fluid chamber adapted for containing a driving fluid therein, and a driving fluid piston movable within the driving fluid chamber. A gas compression cylinder having a gas compression chamber adapted for holding a gas therein and a gas piston movable within the gas compression chamber. A buffer chamber located between the driving fluid chamber and the gas compression chamber, the buffer chamber adapted to inhibit movement of at least one non-driving fluid component, when gas is located within the gas compression chamber, from the gas compression chamber into the driving fluid chamber.

[0015] In another embodiment, the present disclosure relates to a gas compressor system that comprises a first driving fluid cylinder having a first driving fluid chamber adapted for containing a first driving fluid therein, and a first driving fluid piston movable within the first driving fluid chamber. A gas compression chamber adapted for holding a

gas therein and a gas piston movable within the gas compression chamber. A first buffer chamber located between the first driving fluid chamber and a first section of the gas compression chamber. A second driving fluid cylinder having a second driving fluid chamber adapted for containing a second driving fluid therein, and a second driving fluid piston movable within the second driving fluid chamber. A second buffer chamber located between the first driving fluid chamber and a second section of the gas compression chamber. The first buffer chamber is adapted to inhibit movement of at least one non-driving fluid component, when gas is located within a first section of the gas compression chamber, from the first section gas compression chamber section into the first driving fluid chamber. The second buffer chamber is adapted to inhibit movement of at least one non-driving fluid component, when gas is located within a second section of the gas compression chamber, from the second section of the gas compression chamber into the second driving fluid chamber.

[0016] In a further embodiment, the present disclosure relates to a gas compressor that comprises a driving fluid cylinder having a driving fluid chamber operable for containing a driving fluid therein and a driving fluid piston movable within the driving fluid chamber. A gas compression cylinder having a gas compression chamber operable for holding a gas therein and a gas piston movable within the gas compression chamber. A buffer chamber located between the driving fluid chamber and the gas compression chamber, the buffer chamber configured and operable to inhibit movement of at least one non-driving fluid component from the gas compression chamber to substantially avoid contamination of the driving fluid, when gas is located within the gas compression chamber.

[0017] In another embodiment, the present disclosure relates to a gas compressor that comprises a driving fluid cylinder having a driving fluid chamber operable for containing a driving fluid therein and a driving fluid piston movable within the driving fluid chamber. A gas compression cylinder having a gas compression chamber operable for holding natural gas therein and a gas piston movable within the gas compression chamber. A buffer chamber located between the driving fluid chamber and the gas compression chamber, the buffer chamber containing a non-natural gas component so as to substantially avoid contamination of the driving fluid in the driving fluid chamber, when gas is located within the gas compression chamber.

[0018] In some embodiments, it is desirable to provide a gas compressor system that can compensate for variances within the system which can alter the gas compression. Further, it is also desirable to achieve a smooth transition of a piston moving within the gas compression chamber to cause said gas compression, between a drive stroke providing movement to the right and a drive stroke providing movement to the left, in order to provide longer equipment life of the gas compressor system and to reduce wear of the system. It is further desirable for the drive stroke of the piston to travel along a pre-defined distance of the gas compression chamber (e.g. close to a full length of the chamber) in order to achieve maximum gas compression without physically abutting the ends of the gas compression chamber.

[0019] In at least some of the embodiments presented herein, the buffer chamber described herein may not be

needed within the gas compressor system which adaptively controls a gas compressor to improve gas compression.

BRIEF DESCRIPTION OF THE DRAWINGS

[0020] In the figures, which illustrate example embodiments:

[0021] FIG. 1 is a schematic view of an oil and gas producing well system;

[0022] FIG. 1A is an enlarged schematic view of a portion of the system of FIG. 1;

[0023] FIG. 1B is an enlarged view of part of the system of FIG. 1;

[0024] FIG. 1C is an enlarged view of another part of the system of FIG. 1;

[0025] FIG. 1D is a schematic view of an oil and gas well producing system like the system of FIG. 1 but with an alternate lift system;

[0026] FIG. 2 is a side view of a gas compressor forming part of the system of FIG. 1;

[0027] FIGS. 3(i) to (iv) are side views of the gas compressor or FIG. 2 showing a cycle of operation;

[0028] FIG. 4 is a schematic side view of the gas compressor of FIG. 2;

[0029] FIG. 5 is a perspective view of a gas compressor system including the gas compressor of FIG. 2 forming part of an oil and gas producing well systems of FIG. 1 or 1D;

[0030] FIG. 6 is a perspective view of a portion of the gas compressor system of FIG. 5 with some parts thereof exploded;

[0031] FIG. 7 is a schematic diagram a gas compressor system including the gas compressor of FIG. 2;

[0032] FIG. 8 is a perspective exploded view of a gas compressor substantially like the gas compressor of FIG. 2;

[0033] FIG. 8A is enlarged view of the portion marked FIG. 8A in FIG. 8;

[0034] FIG. 8B is enlarged view of the portion marked FIG. 8B in FIG. 8;

[0035] FIG. 9A is a perspective view of the gas compressor of FIG. 2;

[0036] FIG. 9B is a top view of the gas compressor of FIG. 2;

[0037] FIG. 9C is a side view of the gas compressor of FIG. 2;

[0038] FIG. 10A is a schematic diagram of an gas compressor system;

[0039] FIG. 10B is a diagram illustrating the pressure profile in different pump cycles during use of the pump unit shown in FIG. 10A;

[0040] FIGS. 11(a), 11(b), 11(c), 11(d), and 11(e) are schematic views of the gas compressor of FIG. 10A during various stages of operation;

[0041] FIG. 12 is a graph illustrating a lag time factor associated with changes in velocity of a piston stroke in the gas compressor of FIG. 10A;

[0042] FIG. 13 is a graphical depiction of waveforms for controlling operation of components of the compressor shown in FIG. 10A;

[0043] FIG. 14 is a process flowchart showing blocks of code for directing the controller of FIG. 10A to control the operation of the piston strokes of the gas compressor shown in FIG. 10A;

[0044] FIGS. 15(a), 15(b), and 15(c) are side views of the gas compressor shown in FIG. 10A, during various stages of movement of the gas piston and hydraulic pistons of FIG. 10A;

[0045] FIG. 16 is a schematic view of the gas compressor of FIG. 10A during one stage of operation; and

[0046] FIG. 17 is a line graph showing a realistic control (pump) signal applied to a hydraulic pump for driving a gas compressor and the corresponding pressure responses at the output ports of the pump.

DETAILED DESCRIPTION

[0047] With reference to FIGS. 1, 1A, 1B and 1C, an example oil and gas producing well system 100 is illustrated schematically that may be installed at, and in, a well shaft (also referred to as a well bore) 108 and may be used for extracting liquid and/or gases (e.g. oil and/or natural gas) from an oil and gas bearing reservoir 104.

[0048] Extraction of liquids including oil as well as other liquids such as water from reservoir 104 may be achieved by operation of a down-well pump 106 positioned at the bottom of well shaft 108. For extracting oil from reservoir 104, down-well pump 106 may be operated by the up-and-down reciprocating motion of a sucker rod 110 that extends through the well shaft 108 to and out of a well head 102. It should be noted that in some applications, well shaft 108 may not be oriented entirely vertically, but may have horizontal components and/or portions to its path.

[0049] Well shaft 108 may have along its length, one or more generally hollow cylindrical tubular, concentrically positioned, well casings 120a, 120b, 120c, including an inner-most production casing 120a that may extend for substantially the entire length of the well shaft 108. Intermediate casing 120b may extend concentrically outside of production casing 120a for a substantial length of the well shaft 108, but not to the same depth as production casing 120a. Surface casing 120c may extend concentrically around both production casing 120a and intermediate casing 120b, but may only extend from proximate the surface of the ground level, down a relatively short distance of the well shaft 108. The casings 120a, 120b, 120c may be made from one or more suitable materials such as for example steel. Casings 120a, 120b, 120c may function to hold back the surrounding earth/other material in the sub-surface to maintain a generally cylindrical tubular channel through the sub-surface into the oil/natural gas bearing formation 104. Casings 120a, 120b, 120c may each be secured and sealed by a respective outer cylindrical layer of material such as layers of cement 111a, 111b, 111c which may be formed to surround casings 120a-120c in concentric tubes that extend substantially along the length of the respective casing 120a-120c. Production tubing 113 may be received inside production casing 120a and may be generally of a constant diameter along its length and have an inner tubing passage-way/annulus to facilitate the communication of liquids (e.g. oil) from the bottom region of well shaft 108 to the surface region. Casings 120a-120c generally, and casing 120a in particular, can protect production tubing 120 from corrosion, wear/damage from use. Along with other components that constitute a production string, a continuous passageway (a tubing annulus) 107 from the region of pump 106 within the reservoir 104 to well head 102 is provided by production tubing 113. Tubing annulus 107 provides a passageway for sucker rod 110 to extend and within which to move and

provides a channel for the flow of liquid (oil) from the bottom region of the well shaft **108** to the region of the surface.

[0050] An annular casing passageway or gap **121** (referred to herein as a casing annulus) is typically provided between the inward facing generally cylindrical surface of the production casing **120a** and the outward facing generally cylindrical surface of production tubing **113**. Casing annulus **121** typically extends along the co-extensive length of inner casing **120a** and production tubing **113** and thus provides a passageway/channel that extends from the bottom region of well shaft **108** proximate the oil/gas bearing formation **104** to the ground surface region proximate the top of the well shaft **108**. Natural gas (that may be in liquid form in the reservoir **104**) may flow from reservoir **104** into the well shaft **108** and may be, or transform into, a gaseous state and then flow upwards through casing annulus **121** towards well head **102**. In some situations, such as with a newly formed well shaft **108**, the level of the liquid (mainly oil and natural gas in solution) may actually extend a significant way from the bottom/end of the well shaft **108** to close to the surface in both the tubing annulus **107** and the casing annulus **121**, due to relatively high downhole pressures.

[0051] Down-well pump **106** may have a plunger **103** that is attached to the bottom end region of sucker rod **110** and plunger **103** may be moved downwardly and upwardly within a pump chamber by sucker rod **110**. Down well pump **106** may include a one way travelling valve **112** which is a mobile check valve which is interconnected with plunger **103** and which moves in up and down reciprocating motion with the movement of sucker rod **110**. Down well pump **106** may also include a one way standing intake valve **114** that is stationary and attached to the bottom of the barrel of pump **106**/production tubing **113**. Travelling valve **112** keeps the liquid (oil) in the channel **107** of production tubing **113** during the upstroke of the sucker rod **110**. Standing valve **114** keeps the fluid (oil) in the channel **107** of the production tubing **113** during the downstroke of sucker rod **110**. During a downstroke of sucker rod **110** and plunger **103**, travelling valve **112** opens, admitting liquid (oil) from reservoir **104** into the annulus of production tubing **113** of down-well pump **106**. During this downstroke, one-way standing valve **114** at the bottom of well shaft **108** is closed, preventing liquid (oil) from escaping.

[0052] During each upstroke of sucker rod **110**, plunger **103** of down-well pump **106** is drawn upwardly and travelling valve **112** is closed. Thus, liquid (oil) drawn in through one-way valve **112** during the prior downstroke can be raised. And as standing valve **114** opens during the upstroke, liquid (oil) can enter production tubing **113** below plunger **103** through perforations **116** in production casing **120a** and cement layer **111a**, and past standing valve **114**. Successive upstrokes of down-well pump **106** form a column of liquid/oil in well shaft **108** above down-well pump **106**. Once this column of liquid/oil is formed, each upstroke pushes a volume of oil toward the surface and well head **102**. The liquid/oil, eventually reaches a T-junction device **140** which has connected thereto an oil flow line **133**. Oil flow line **133** may contain a valve device **138** that is configured to permit oil to flow only towards a T-junction interconnection **134** to be mixed with compressed natural gas from piping **130** that is delivered from a gas compressor system **126** and then together both flow way in a main oil/gas output flow line **132**.

[0053] Sucker rod **110** may be actuated by a suitable lift system **118** that may for example as illustrated schematically in FIG. 1, be a pump jack system **119** that may include a walking beam mechanism **117** driven by a pump jack drive mechanism **120** (often referred to as a prime mover). Prime mover **120** may include a motor **123** that is powered for example by electricity or a supply of natural gas, such as for example, natural gas produced by oil and gas producing well system **100**. Prime mover **120** may be interconnected to and drive a rotating counter weigh device **122** that may cause the pivoting movement of the walking beam mechanism **120** that causes the reciprocating upward and downward movement of sucker rod **110**.

[0054] As shown in FIG. 1 D, lift mechanism **1118** may in other embodiments be a hydraulic lift system **1119** that includes a hydraulic fluid based power unit **1120** that supplies hydraulic fluid through a fluid supply circuit to a master cylinder apparatus **1117** to controllably raise and lower the sucker rod **110**. The power unit **1120** may include a suitable controller to control the operation of the hydraulic lift system **1119**.

[0055] With reference to FIGS. 1 to 1C, natural gas exiting from annulus **121** of casing **120** may be fed by suitable piping **124** through valve device **128** to inter-connected gas compressor system **126**. Piping **124** may be made of any suitable material(s) such as steel pipe or flexible hose such as Aeroquip FC 300 AOP elastomer tubing made by Eaton Aeroquip LLC. In normal operation of system **100**, the flow of natural gas communicated through piping **124** to gas compressor system **126** is not restricted by valve device **128** and the natural gas will flow there through. Valve **128** may be closed (e.g. manually) if for some reason it is desired to shut off the flow of natural gas from annulus **121**.

[0056] Compressed natural gas that has been compressed by gas compressor system **126** may be communicated via piping **130** through a one way check valve device **131** to interconnect with oil flow line **133** to form a combined oil and gas flow line **132** which can deliver the oil and gas therein to a destination for processing and/or use. Piping **130** may be made of any suitable material(s) such as steel pipe or flexible hose such as Aeroquip FC 300 AOP elastomer tubing made by Eaton Aeroquip LLC.

[0057] Gas compressor system **126** may include a gas compressor **150** that is driven by a driving fluid. As indicated above, natural gas from casing annulus **121** of well shaft **108** may be supplied by piping **124** to gas compressor system **126**. Natural gas may be compressed by gas compressor **150** and then communicated via piping **130** through a one way check valve device **131** to interconnect with oil flow line **133** to form combined oil and gas flow line **132**.

[0058] The driving fluid for driving gas compressor **150** may be any suitable fluid such as a fluid that is substantially incompressible, and may contain anti-wear additives or constituents. The driving fluid may, for example, be a suitable hydraulic fluid. For example, the hydraulic fluid may be SKYDROL™ aviation fluid manufactured by Solutia Inc. The hydraulic fluid may for example be a fluid suitable as an automatic transmission fluid, a mineral oil, a bio-degradable hydraulic oil, or other suitable synthetic or semi-synthetic hydraulic fluid.

[0059] Hydraulic gas compressor **150** may be in hydraulic fluid communication with a hydraulic fluid supply system which may provide an open loop or closed loop hydraulic fluid supply circuit. For example gas compressor **150** may be

in hydraulic fluid communication with a hydraulic fluid supply system **1160** as depicted in FIG. 10A.

[0060] Turning now to FIGS. 2 and 7, hydraulic gas compressor **150** may have first and second, one-way acting, hydraulic cylinders **152a**, **152b** positioned at opposite ends of hydraulic gas compressor **150**. Cylinders **152a**, **152b** are each configured to provide a driving force that acts in an opposite direction to each other, both acting inwardly towards each other and towards a gas compression cylinder **180**. Thus, positioned generally inwardly between hydraulic cylinders **152a**, **152b** is gas compression cylinder **180**. Gas compression cylinder **180** may be divided into two gas compression chamber sections **181a**, **181b** by a gas piston **182**. In this way, gas such as natural gas in each of the gas chamber sections **181a**, **181b**, may be alternately compressed by alternating, inwardly directed driving forces of the hydraulic cylinders **152a**, **152b** driving the reciprocal movement of gas piston **182** and piston rod **194**.

[0061] Gas compression cylinder **180** and hydraulic cylinders **152a**, **152b** may have generally circular cross-sections although alternately shaped cross sections are possible in some embodiments.

[0062] Hydraulic cylinder **152a** may have a hydraulic cylinder base **183a** at an outer end thereof. A first hydraulic fluid chamber **186a** may thus be formed between a cylinder barrel/tubular wall **187a**, hydraulic cylinder base **183a** and hydraulic piston **154a**. Hydraulic cylinder base **183a** may have a hydraulic input/output fluid connector **1184a** that is adapted for connection to hydraulic fluid communication line **1166a**. Thus hydraulic fluid can be communicated into and out of first hydraulic fluid chamber **186a**.

[0063] At the opposite end of gas compressor **150**, is a similar arrangement. Hydraulic cylinder **152b** has a hydraulic cylinder base **183b** at an outer end thereof. A second hydraulic fluid chamber **186b** may thus be formed between a cylinder barrel/tubular wall **187b**, hydraulic cylinder base **183b** and hydraulic piston **154b**. Hydraulic cylinder base **183b** may have an input/output fluid connector **1184b** that is adapted for connection to a hydraulic fluid communication line **1166b**. Thus hydraulic fluid can be communicated into and out of second hydraulic fluid chamber **186b**.

[0064] In embodiments such as is illustrated in FIG. 7, the driving fluid connectors **1184a**, **1184b** may each connect to a single hydraulic line **1166a**, **1166b** that may, depending upon the operational configuration of the system, either be communicating hydraulic fluid to, or communicating hydraulic fluid away from, each of hydraulic fluid chamber **186a** and hydraulic fluid chamber **186b**, respectively. However, other configurations for communicating hydraulic fluid to and from hydraulic fluid chambers **186a**, **186b** are possible.

[0065] As indicated above, gas compression cylinder **180** is located generally between the two hydraulic cylinders **152a**, **152b**. Gas compression cylinder **180** may be divided into the two adjacent gas chamber sections **181a**, **181b** by gas piston **182**. First gas chamber section **181a** may thus be defined by the cylinder barrel/tubular wall **190**, gas piston **182** and first gas cylinder head **192a**. The second gas chamber section **181b** may thus be defined by the cylinder barrel/tubular wall **190**, gas piston **182** and second gas cylinder head **192b** and formed on the opposite side of gas piston **182** to first gas chamber section **181a**.

[0066] The components forming hydraulic cylinders **154a**, **154b** and gas compression cylinder **180** may be made from

any one or more suitable materials. By way of example, barrel **190** of gas compression cylinder **180** may be formed from chrome plated steel; the barrel of hydraulic cylinders **152a**, **152b**, may be made from a suitable steel; gas piston **182** may be made from T6061aluminum; the hydraulic pistons **154a**, **154b** may be made generally from ductile iron; and piston rod **194** may be made from induction hardened chrome plated steel.

[0067] The diameter of hydraulic pistons **154a**, **154b** may be selected dependent upon the required output gas pressure to be produced by gas compressor **150** and a diameter (for example about 3 inches) that is suitable to maintain a desired pressure of hydraulic fluid in the hydraulic fluid chambers **186a**, **186b** (for example—a maximum pressure of about 2800 psi).

[0068] Hydraulic pistons **154a**, **154b** may also include seal devices **196a**, **196b** respectively at their outer circumferential surface areas to provide fluid/gas seals with the inner wall surfaces of respective hydraulic cylinder barrels **187a**, **187b** respectively. Seal devices **196a**, **196b**, may substantially prevent or inhibit movement of hydraulic fluid out of hydraulic fluid chambers **186a**, **186b** during operation of hydraulic gas compressor **150** and may prevent or at least inhibit the migration of any gas/liquid that may be in respective adjacent buffer chambers **195a**, **195b** (as described further hereafter) into hydraulic fluid chambers **186a**, **186b**.

[0069] Also with reference now to FIGS. 8, 8A and 8B, hydraulic piston seal devices **196a**, **196b** may include a plurality of polytetrafluoroethylene (PTFE) (e.g. Teflon™) seal rings and may also include Hydrogenated nitrile butadiene rubber (HNBR) energizers/energizing rings for the seal rings. A mounting nut **188a**, **188b** may be threadably secured to the opposite ends of piston rod **194** and may function to secure the respective hydraulic pistons **154a**, **154b** onto the end of piston rod **194**.

[0070] The diameter of the gas piston **182** and corresponding inner surface of gas cylinder barrel **190** will vary depending upon the required volume of gas and may vary widely (e.g. from about 6 inches to 12 inches or more). In one example embodiment, hydraulic pistons **154a**, **154b** have a diameter of 3 inches; piston rod **194** has a diameter of 2.5 inches and gas piston **182** has a diameter of 8 inches.

[0071] Gas piston **182** may also include a conventional gas compression piston seal device at its outer circumferential surfaces to provide a seal with the inner wall surface of gas cylinder barrel **190** to substantially prevent or inhibit movement of natural gas and any additional components associated with the natural gas, between gas compression cylinder sections **181a**, **181b**. Gas piston seal device may also assist in maintaining the gas pressure differences between the adjacent gas compression cylinder sections **181a**, **181b**, during operation of hydraulic gas compressor **150**.

[0072] As noted above, hydraulic pistons **154a**, **154b** may be formed at opposite ends of a piston rod **194**. Piston rod **194** may pass through gas compression cylinder sections **181a**, **181b** and pass through a sealed (e.g. by welding) central axial opening **191** through gas piston **182** and be configured and adapted so that gas piston **182** is fixedly and sealably mounted to piston rod **194**.

[0073] Piston rod **194** may also pass through axially oriented openings in head assemblies **200a**, **200b** that may be located at opposite ends of gas cylinder barrel **190**. Thus, reciprocating axial/longitudinal movement of piston rod **194**

will result in reciprocating synchronous axial/longitudinal movement of each of hydraulic pistons **154a**, **154b** in respective hydraulic fluid chambers **186a**, **186b**, and of gas piston **182** within gas compression chamber sections **181a**, **181b** of gas compression cylinder **180**.

[0074] Located on the inward side of hydraulic piston **154a**, within hydraulic cylinder **154a**, between hydraulic fluid chamber **186a** and gas compression cylinder section **181a**, may be located first buffer chamber **195a**. Buffer chamber **195a** may be defined by an inner surface of hydraulic piston **154a**, the cylindrical inner wall surface of hydraulic cylinder barrel **187a**, and hydraulic cylinder head **189a**.

[0075] Similarly, located on the inward side of hydraulic piston **154b**, within hydraulic cylinder **154b**, between hydraulic fluid chamber **186b** and gas compression cylinder section **181b**, may be located second buffer chamber **195b**. Buffer chamber **195b** may be defined by an inner surface of hydraulic piston **154b**, the cylindrical inner wall surface of cylinder barrel **187b**, and hydraulic cylinder head **189b**.

[0076] As hydraulic pistons **154a**, **154b** are mounted at opposite ends of piston rod **194**, piston rod **194** also passes through buffer chambers **195a**, **195b**.

[0077] With particular reference now to FIGS. **2**, **6**, **8**, **8A-C**, and **9A-C** and **13A-C**, head assembly **200a** may include hydraulic cylinder head **189a** and gas cylinder head **192a** and a hollow tubular casing **201a**. Hydraulic cylinder head **189a** may have a generally circular hydraulic cylinder head plate **206a** formed or mounted within casing **201a** (FIG. **8B**).

[0078] A barrel flange plate **290a** (FIG. **9A**), hydraulic cylinder head plate **206a** (FIG. **8B**) and a gas cylinder head plate **212a** may have casing **201a** disposed there between. Gas cylinder head plate **212a** may be interconnected to an inward end of hollow tubular casing **201a** for example by welds or the two parts may be integrally formed together. In other embodiments, hollow tubular casing **201a** may be integrally formed with both hydraulic cylinder head plate **206a** and gas cylinder head plate **212a**.

[0079] Hydraulic cylinder barrel **187a** may have an inward end **179a**, interconnected such as by welding to the outward facing edge surface of a barrel flange plate **290a**. Barrel flange plate **290a** may be configured as shown in FIGS. **2**, **8A-C**, and **9A-C**.

[0080] Barrel flange plate **290a** may be connected to the hydraulic cylinder head plate **206a** by bolts **217** (FIG. **8**) received in threaded openings **218** of outward facing surface **213a** of hydraulic head plate **206a** (FIGS. **8** and **8B**). A gas and liquid seal may be created between the mating surfaces of hydraulic head plate **206a** and barrel flange plate **290a**. A sealing device may be provided between these plate surfaces such as TEFLON hydraulic seals and buffers.

[0081] Gas cylinder barrel **190** may have an end **155a** (FIG. **8B**) interconnected to the inward facing surface of gas cylinder head plate **212a** such as by passing first threaded ends of each of the plurality of tie rods **193** through openings in head plate **212a** and securing them with nuts **168**.

[0082] Piston rod **194** may have a portion that moves longitudinally within the inner cavity formed through openings within barrel flange plate **290a**, hydraulic cylinder head plate **206a** and gas cylinder head plate **212a** and within tubular casing **210a**.

[0083] A structure and functionality corresponding to the structure and functionality just described in relation to

hydraulic cylinder **152a**, buffer chamber **195a**, and gas compression cylinder section **181a**, may be provided on the opposite side of hydraulic gas compression cylinder **150** in relation to hydraulic cylinder **152b**, buffer chamber **195b**, and gas compression cylinder section **181b**.

[0084] Thus with particular reference to FIGS. **8**, **8A** and **8B**, head assembly **200b** may include hydraulic cylinder head **189b**, gas cylinder head **192b** and a hollow tubular casing **201b**. Hydraulic cylinder head **189b** may have a hydraulic cylinder head plate **206b** formed or mounted within casing **201b** (FIG. **8A**)

[0085] A barrel flange plate **290b**/hydraulic cylinder head plate **206b** and a gas cylinder head plate **212b** (FIGS. **8** and **8A**) may have casing **201b** generally disposed there between. Gas cylinder head plate **212b** may be interconnected to hollow tubular casing **201b** for example by welds or the two parts may be integrally formed together. In other embodiments, hollow tubular casing **201b** may be integrally formed with hydraulic cylinder head plate **206b** and gas cylinder head plate **212b**.

[0086] Hydraulic cylinder barrel **187b** (FIG. **9A**) may have an inward end **179b**, interconnected such as by welding to the outward facing edge surface of a barrel flange plate **290b**. Barrel flange plate **290b** may also be configured as shown in FIGS. **2**, **8**, **8A-C**, and FIGS. **9A-C**.

[0087] Barrel flange plate **290b** may be connected to the hydraulic cylinder head plate **206b** by bolts **217** received in threaded openings **218b** of outward facing surface **213b** of hydraulic head plate **206b** (FIG. **9B**). A gas and liquid seal may be created between the mating surfaces of hydraulic head plate **206b** and barrel flange plate **290b**. A sealing device may be provided between these plate surfaces such as TEFLON hydraulic seals and buffers.

[0088] Gas cylinder barrel **190** may have an end **155b** (FIG. **9A**) interconnected to the inward facing surface of gas cylinder head plate **212b** such as by passing first threaded ends of each of the plurality of tie rods **193** through openings in head plate **212b** and securing them with nuts **168**.

[0089] Piston rod **194** may have a portion that moves longitudinally within the inner cavity formed through openings within hydraulic cylinder head plate **206b** and gas cylinder head plate **212b** and within tubular casing **210b**.

[0090] With particular reference now to FIGS. **8**, **8A** and **8B**, two head sealing O-rings **308a**, **308b** may be provided and which may be made from highly saturated nitrile-butadiene rubber (HNBR). One O-ring **308a** may be located between a first circular edge groove **216a** at end **155a** of gas cylinder barrel **190** and the inward facing surface of gas cylinder head plate **212a**. O-ring **308a** may be retained in a groove in the inward facing surface of gas cylinder head plate **212a**. O-ring **308b** may be located between a second opposite circular edge groove **216b** of at the opposite end of gas cylinder barrel **190** and the inward facing surface of gas cylinder head plate **212b**. O-ring **308b** may be retained in a groove in the inward facing surface of gas cylinder head plate **212b**. In this way gas seals are provided between gas compression chamber sections **181a**, **181b** and their respective gas cylinder head plates **212a**, **212b**.

[0091] By securing threaded both opposite ends of each of the plurality of tie rods **193** through openings in gas cylinder head plates **212a**, **212b** and securing them with nuts **168**, tie rods **193** will function to tie together the head plates **212a** and **212b** with gas cylinder barrel **190** and O-rings **308a**,

308b securely held there between and providing a sealed connection between cylinder barrel **190** and head plates **212a, 212b**.

[0092] Seal/wear devices **198a, 198b** may be provided within casing **201a** to provide a seal around piston rod **194** and with an inner surface of casing **201a** to prevent or limit the movement of natural gas out of gas compression cylinder section **181a**, into buffer chamber **195a**. Corresponding seal/wear devices may be provided within casing **201b** to provide a seal around piston rod **194** and with an inner surface of casing **201b** to prevent or limit the movement of natural gas out of gas compression cylinder section **181b**, into buffer chamber **195b**. These seal devices **198a, 198b** may also prevent or at least limit/inhibit the movement of other components (such as contaminants) that have been transported with the natural gas from well shaft **108** into gas compression cylinder sections **181a, 181b**, from migrating into respective buffer chambers **195a, 195b**.

[0093] While in some embodiments, the gas pressure in gas compression chamber sections **181a, 181b** will remain generally, if not always, above the pressure in the adjacent respective buffer chambers **195a, 195b**, the seal/wear devices **198a, 198b** may in some situations prevent migration of gas and/or liquid that may be in buffer chambers **195a, 195b** from migrating into respective gas compression chamber sections **181a, 181b**. The seal/wear devices **198a, 198b** may also assist to guide piston rod **194** and keep piston rod **194** centred in the casings **201a, 201b** and absorb transverse forces exerted upon piston rod **194**.

[0094] Also, with particular reference to FIGS. **8, 8A** and **8B**, each seal device **198a, 198b** may be mounted in a respective casing **201a, 201b**. Associated with each head assembly **200a, 200b** may also be a rod seal retaining nut **151** which may be made from any suitable material, such as for example aluminium bronze. A rod seal retaining nut **151** may be axially mounted around piston rod **194**. Rod seal retaining nut **151** may be provided with inwardly directed threads **156**. The threads **156** of rod sealing nut **151** may engage with internal mating threads in opening **153** of the respective casing **201a, 201b**. By tightening rod sealing nut **151**, components of sealing devices **198a, 198b** may be axially compressed within casing **201a, 201b**. The compression causes components of the sealing devices **198a, 198b** to be pushed radially outwards to engage an inner cylindrical surface of the respective casings **201a, 201b** and radially inwards to engage the piston rod **194**. Thus seal devices **198a, 198b** are provided to function as described above in providing a sealing mechanism.

[0095] As each rod seal retaining nut **151** can be relatively easily unthreaded from engagement with its respective casing **201a, 201b**, maintenance and/or replacement of one or more components of seal devices **198a, 198b** is made easier. Additionally, by turning a rod seal retaining nut **151** may be engaged to thread the rod seal retaining nut further into opening **153** of the casing, adjustments can be made to increase the compressive load on the components of the sealing devices **198a, 198b** to cause them to be being pushed radially further outwards into further and stronger engagement with an inner cylindrical surface of the respective casings **201a, 201b** and further inwards to engage with the piston rod **194**. Thus the level of sealing action/force provided by each seal device **198a, 198b** may be adjusted.

[0096] However, even with an effective seal provided by the sealing devices **198a, 198b**, it is possible that small

amounts of natural gas, and/or other components such as hydrogen sulphide, water, oil may still at least in some circumstances be able to travel past the sealing devices **198a, 198b** into respective buffer chambers **195a, 195b**. For example, oil may be adhered to the surface of piston rod **194** and during reciprocating movement of piston rod **194**, it may carry such other components from the gas compression cylinder section **181a, 181b** past sealing devices **198a, 198b**, into an area of respective cylinder barrels **187a, 187b** that provide respective buffer chambers **195a, 195b**. High temperatures that typically occur within gas compression chamber sections **181a, 181b** may increase the risk of contaminants being able to pass seal devices **198a, 198b**. However buffer chambers **195a, 195b** each provide an area that may tend to hold any contaminants that move from respective gas compression chamber sections **181a, 181b** and restrict the movement of such contaminants into the areas of cylinder barrels that provide hydraulic cylinder fluid chambers **186a, 186b**.

[0097] Mounted on and extending within cylinder barrel **187a** close to hydraulic cylinder head **189a**, is a proximity sensor **157a**. Proximity sensor **157a** is operable such that during operation of gas compressor **150**, as piston **154a** is moving from left to right, just before piston **154a** reaches the position shown in FIG. **3(i)**, proximity sensor **157a** will detect the presence of hydraulic piston **154a** within hydraulic cylinder **152a** at a longitudinal position that is shortly before the end of the stroke. Sensor **157a** will then send a signal to controller **200**, in response to which controller **200** can take steps to change the operational mode of hydraulic fluid supply system **1160** (FIG. **7**).

[0098] Similarly, mounted on and extending within cylinder barrel **187b** close to hydraulic cylinder head **189b**, is another proximity sensor **157b**. Proximity sensor **157b** is operable such that during operation of gas compressor **150**, as piston **154b** is moving from right to left, just before piston **154b** reaches the position shown in FIG. **5(iii)**, proximity sensor **157b** will detect the presence of hydraulic piston **154b** within hydraulic cylinder **152b** at a longitudinal position that is shortly before the end of the stroke. Proximity sensor **157b** will then send a signal to controller **200**, in response to which controller **200** can take steps to change the operational mode of hydraulic fluid supply system **1160**.

[0099] Proximity sensors **157a, 157b** may be in communication with controller **200**. In some embodiments, proximity sensors **157a, 157b** may be implemented using inductive proximity sensors, such as model BI 2-M12-Y1X-H1141 sensors manufactured by Turck, Inc. These inductive sensors are operable to generate proximity signals responsive to the proximity of a metal portion of piston rod **194** proximate to each of hydraulic piston **154a, 154b**. For example sensor rings may be attached around piston rod **194** at suitable positions towards, but spaced from, hydraulic pistons **154a, 154b** respectively such as annular collar **199b** in relation to hydraulic piston **154b**—FIGS. **6** and **8**. Proximity sensors **157a, 157b** may detect when collars **199a, 199b** on piston rod **194** pass by. Steel annular collars **199a, 199b** may be mounted to piston rod **194** and may be held on piston rod **194** with set screws and a LOCTITE™ adhesive made by Henkel Corporation.

[0100] It is possible for controller **200** (FIG. **7**) to be programmed in such manner to control the hydraulic fluid supply system **1160** in such a manner as to provide for a relatively smooth slowing down, a stop, reversal in direction

and speeding up of piston rod **194** along with the hydraulic pistons **154a**, **154b** and gas piston **182** as the piston rod **194**, hydraulic pistons **154a**, **154b** and gas piston **182** transition between a drive stroke providing movement to the right to a drive stroke providing the stroke to the left and back to a stroke providing movement to the right.

[0101] An example hydraulic fluid supply system **1160** for driving hydraulic pistons **154a**, **154b** of hydraulic cylinders **152a**, **152b** of hydraulic gas compressor **150** in reciprocating movement is illustrated in FIG. 7. Hydraulic fluid supply subsystem **1160** may be a closed loop system and may include a pump unit **1174**, hydraulic fluid communication lines **1163a**, **1163b**, **1166a**, **1166b**, and a hot oil shuttle valve device **1168**. Shuttle valve device **1168** may be for example a hot oil shuttle valve device made by Sun Hydraulics Corporation under model XRDCLNN-AL.

[0102] Fluid communication line **1163a** fluidly connects a port S of pump unit **1174** to a port Q of shuttle valve **1168**. Fluid communication line **1163b** fluidly connects a port P of pump **1174** to a port R of shuttle valve **1168**. Fluid communication line **1166a** fluidly connects a port V of shuttle valve **1168** to a port **1184a** of hydraulic cylinder **152a**. Fluid communication line **1166b** fluidly connects a port W of shuttle valve **1168** to a port **1184b** of hydraulic cylinder **152b**.

[0103] An output port M of shuttle valve **1168** may be connected to an upstream end of a bypass fluid communication line **1169** having a first portion **1169a**, a second portion **1169b** and a third portion **1169c** that are arranged in series. A filter **1171** may be interposed in bypass line **1169** between portions **1169a** and **1169b**. Filter **1171** may be operable to remove contaminants from hydraulic fluid flowing from shuttle valve device **1168** before it is returned to reservoir **1172**. Filter **1171** may for example include a type HMK05/25 5 micro-m filter device made by Donaldson Company, Inc. The downstream end of line portion **1169b** joins with the upstream end of line portion **1169c** at a T-junction where a downstream end of a pump case drain line **1161** is also fluidly connected. Case drain line **1161** may drain hydraulic fluid leaking within pump unit **1174**. Fluid communication line portion **1169c** is connected at an opposite end to an input port of a thermal valve device **1142**. Depending upon the temperature of the hydraulic fluid flowing into thermal valve device **1142** from communication line portion **1169c** of bypass line **1169**, thermal valve device **1142** directs the hydraulic fluid to either fluid communication line **1141a** or **1141b**. If the temperature of the hydraulic fluid flowing into thermal valve device **1142** is greater than a set threshold level, valve device **1142** will direct the hydraulic fluid through fluid communication line **1141a** to a cooling device **1143** where hydraulic fluid can be cooled before being passed through fluid communication line **1141c** to reservoir **1172**. If the hydraulic fluid entering fluid valve device **1142** does not require cooling, then thermal valve **1142** will direct the hydraulic fluid received therein from communication line portion **1169c** to communication line **1141b** which leads directly to reservoir **1172**. An example of a suitable thermal valve device **1142** is a model 67365-110F made by TTP (formerly Thermal Transfer Products). An example of a suitable cooler **1143** is a model BOL-16-216943 also made by TTP.

[0104] Drain line **1161** connects output case drain ports U and T of pump unit **1174** to a T-connection in communication line **1169b** at a location after filter **1171**. Thus any

hydraulic fluid directed out of case drain ports U/T of pump unit **1174** can pass through drain line **1161** to the T-connection of communication line portions **1169b**, **1169c**, (without going through the filter device **1171**) where it can mix with any hydraulic fluid flowing from filter **1171** and then flow to thermal valve device **1142** where it can either be directed to cooler **1143** before flowing to reservoir **1172** or be directed directly to reservoir **1172**. By not passing hydraulic fluid from case drain **1161** through relatively fine filter **1171**, the risk of filter **1171** being clogged can be reduced. It will be noted that filter **1182** provides a secondary filter for fluid that is re-charging pump unit **1174** from reservoir **1172**.

[0105] Hydraulic fluid supply system **1160** may include a reservoir **1172** may utilize any suitable driving fluid, which may be any suitable hydraulic fluid that is suitable for driving the hydraulic cylinders **152a**, **152b**.

[0106] Cooler **1143** may be operable to maintain the hydraulic fluid within a desired temperature range, thus maintaining a desired viscosity. For example, in some embodiments, cooler **1143** may be operable to cool the hydraulic fluid when the temperature goes above about 50° C. and to stop cooling when the temperature falls below about 45° C. In some applications such as where the ambient temperature of the environment can become very cold, cooler **1143** may be a combined heater and cooler and may further be operable to heat the hydraulic fluid when the temperature reduces below for example about -10° C. The hydraulic fluid may be selected to maintain a viscosity generally in hydraulic fluid supply system **1160** of between about 20 and about 40 mm² s⁻¹ over this temperature range.

[0107] Hydraulic pump unit **1174** is generally part of a closed loop hydraulic fluid supply system **1160**. Pump unit **1174** includes outlet ports S and P for selectively and alternately delivering a pressurized flow of hydraulic fluid to fluid communication lines **1163a** and **1163b** respectively, and for allowing hydraulic fluid to be returned to pump unit **1174** at ports S and P. Thus hydraulic fluid supply system **1160** may be part of a closed loop hydraulic circuit, except to the extent described hereinafter. Pump unit **1174** may be implemented using a variable-displacement hydraulic pump capable of producing a controlled flow hydraulic fluid alternately at the outlets S and P. In one embodiment, pump unit **1174** may be an axial piston pump having a swashplate that is configurable at a varying angle α . For example pump unit **1174** may be a HPV-02 variable pump manufactured by Linde Hydraulics GmbH & Co. KG of Germany, a model that is operable to deliver displacement of hydraulic fluid of up to about 55 cubic centimeters per revolution at pressures in the range of 58-145 psi. In other embodiments, the pump unit **1174** may be other suitable variable displacement pump, such as a variable piston pump or a rotary vane pump, for example. For the Linde HPV-02 variable pump, the angle α of the swashplate may be adjusted from a maximum negative angle of about -21°, which may correspond to a maximum flow rate condition at the outlet S, to about 0°, corresponding to a substantially no flow condition from either port S or P, and a maximum positive angle of about +21°, which corresponds to a maximum flow rate condition at the outlet P.

[0108] In this embodiment the pump unit **1174** may include an electrical input for receiving a displacement control signal from controller **200**. The displacement control signal at the input is operable to drive a coil of a solenoid (not shown) for controlling the displacement of the pump

unit **1174** and thus a hydraulic fluid flow rate produced alternately at the outlets P and S. The electrical input is connected to a 24VDC coil within the hydraulic pump **1174**, which is actuated in response to a controlled pulse width modulated (PWM) excitation current of between about 232 mA (i_{ou}) for a no flow condition and about 425 mA (i_{L}) for a maximum flow condition.

[0109] For the Linde HPV-02 variable pump unit **1174**, the swashplate is actuated to move to an angle α either $+21^\circ$ or -21° , only when a signal is received from controller **200**. Controller **200** will provide such a signal to pump unit **1174** based on the position of the hydraulic pistons **154a**, **154b** as detected by proximity sensors **157a**, **157b** as described above, which provide a signal to the controller **200** when the gas compressor **150** is approaching the end of a drive stroke in one direction, and commencement of a drive stroke in the opposite direction is required.

[0110] Pump unit **1174** may also be part of a fluid charge system **1180**. Fluid charge system **1180** is operable to maintain sufficient hydraulic fluid within pump unit **1174** and may maintain/hold fluid pressure of for example at least 300 psi at both ports S and P so as to be able to control and maintain the operation of the main pump so it can function to supply a flow of hydraulic fluid under pressure alternately at ports S and P.

[0111] Fluid charge system **1180** may include a charge pump that may be a 16 cc charge pump supplying for example 6-7 gpm and it may be incorporated as part of pump unit **1174**. Charge system **1180** functions to supply hydraulic fluid as may be required by pump unit **1174**, to replace any hydraulic fluid that may be directed from port M of shuttle valve device **1168** through a relief valve associated with shuttle valve device **1168** to reservoir **1172** and to address any internal hydraulic fluid leakage associated with pump unit **1174**. The shuttle valve device **1168** may for example redirect in the range of 3-4 gpm from the hydraulic fluid circuit. The charge pump will then replace the redirected hydraulic fluid 1:1 by maintaining a low side loop pressure.

[0112] The relief valve associated with shuttle valve device **1168** will typically only divert to port M a very small proportion of the total amount of hydraulic fluid circulating in the fluid circuit and which passes through shuttle valve device **1168** into and out of hydraulic cylinders **152a**, **152b**. For example, the relief valve associated with shuttle valve device may only divert approximately 3 to 4 gallons per minute of hydraulic fluid at 200 psi, accounting for example for only about 1% of the hydraulic fluid in the substantially closed loop the hydraulic fluid circuit. This allows at least a portion of the hydraulic fluid being circulated to gas compressor **150** on each cycle to be cooled and filtered.

[0113] The charge pump may draw hydraulic fluid from reservoir **1172** on a fluid communication line **1185** that connects reservoir **1172** with an input port B of pump unit **1174**. The charge pump of pump unit **1174** then directs and forces that fluid to port A where it is then communicated on fluid communication line **1181** to a filter device **1182** (which may for example be a 10 micro-m filter made by Linde).

[0114] Upon passing through filter device **1182** the hydraulic fluid may then enter port F of pump unit **1174** where it will be directed to the fluid circuit that supplies hydraulic fluid at ports S and P. In this way a minimum of 300 psi of pressure of the hydraulic fluid may be maintained during operation at ports S and P. The charge pressure gear

pump may be mounted on the rear of the main pump and driven through a common internal shaft.

[0115] In a swashplate pump, rotation of the swashplate drives a set of axially oriented pistons (not shown) to generate fluid flow. In an embodiment of FIG. 7, the swashplate of the pump unit **1174** is driven by a rotating shaft **1173** that is coupled to a prime mover **1175** for receiving a drive torque. In some embodiments, prime mover **1175** is an electric motor but in other embodiments, the prime mover may be implemented in other ways such as for example by using a diesel engine, gasoline engine, or a gas driven turbine.

[0116] Prime mover **1175** is responsive to a control signal received from controller **200** at a control input to deliver a controlled substantially constant rotational speed and torque at the shaft **1173**. While there may be some minor variations in rotational speed, the shaft **1173** may be driven at a speed that is substantially constant and can for a period of time required, produce a substantially constant flow of fluid alternately at the outlet ports S and P. In one embodiment the prime mover **256** is selected and configured to deliver a rotational speed of about 1750 rpm which is controlled to be substantially constant within about $\pm 1\%$.

[0117] To alternately drive the hydraulic cylinders **152a**, **152b** to provide the reciprocating axial motion of the hydraulic pistons **154a**, **154b** and thus reciprocating motion of gas piston **182**, a displacement control signal is sent from controller **200** to pump unit **1174** and a signal is also provided by controller to prime mover **1175**. In response, prime mover **1175** drives rotating shaft **1173**, to drive the swashplate in rotation. The displacement control signal at the input of pump unit **1174** drives a coil of a solenoid (not shown) to cause the angle α of the swashplate to be adjusted to desired angle such as a maximum negative angle of about -21° , which may correspond to a maximum flow rate condition at the outlet S and no flow at outlet P. The result is that pressurized hydraulic fluid is driven from port S of pump unit **1174** along fluid communication line **1163a** to input port Q of shuttle valve device **1168**. The shuttle valve device **1168** with the lower pressure hydraulic fluid at port R will be configured such that the pressurized hydraulic fluid flows into port Q and will flow out of port V of shuttle valve device **1168** and into and along fluid communication line **1166a** and then will enter hydraulic fluid chamber **186a** of hydraulic cylinder **152a**. The flow of hydraulic fluid into hydraulic fluid chamber **186a** will cause hydraulic piston **154a** to be driven axially in a manner which expands hydraulic fluid chamber **186a**, thus resulting in movement in one direction of piston rod **194**, hydraulic pistons **154a**, **154b** and gas piston **182**.

[0118] During the expansion of hydraulic fluid chamber **186a** as piston **154a** moves within cylinder barrel **187a**, there will be a corresponding contraction in size of hydraulic fluid chamber **186b** of hydraulic cylinder **152b** within cylinder barrel **187b**. This results in hydraulic fluid being driven out of hydraulic fluid chamber **186b** through port **1184b** and into and along fluid communication line **1166b**. The configuration of shuttle valve device **1168** will be such that on this relatively low pressure side, hydraulic fluid can flow into port W and out of port R of shuttle valve device **1168**, then along fluid communication line **1163b** to port P of pump unit **1174**. However, the relief valve associated with shuttle valve device **1168** may, in this operational configuration, direct a small portion of the hydraulic fluid flowing along

line **1166b** to port M for communication to reservoir **1172**, as discussed above. However, most (e.g. about 99%) of the hydraulic fluid flowing in communication line **1166b** will be directed to communication line **1163b** for return to pump unit **1174** and enter at port P.

[0119] When the hydraulic piston **154a** approaches the end of its drive stroke, a signal is sent by proximity sensor **157a** to controller **200** which causes controller **200** to send a displacement control signal to pump unit **1174**. In response to receiving the displacement control signal at the input of pump unit **1174**, a coil of the solenoid (not shown) is driven to cause the angle α of the swashplate of pump unit **1174** to be altered such as to be set at a maximum negative angle of about $+21^\circ$, which may correspond to a maximum flow rate condition at the outlet P and no flow at outlet S. The result is that pressurized hydraulic fluid is driven from port P of pump unit **1174** along fluid communication line **1163b** to port R of shuttle valve device **1168**. The configuration of shuttle valve device **1168** will have been adjusted due to the change in relative pressures of hydraulic fluid in lines **1163a** and **1163b**, such that on this relatively high pressure side, hydraulic fluid can flow into port R and out of port W of shuttle valve device **1168**, then along fluid communication line **1166b** to port **1184b**. Pressurized hydraulic fluid will then enter hydraulic fluid chamber **186b** of hydraulic cylinder **152b**. This will cause hydraulic piston **154b** to be driven in an opposite axial direction in a manner which expands hydraulic fluid chamber **186b**, thus resulting in synchronized movement in an opposite direction of hydraulic cylinders **154a**, **154b** and gas piston **182**.

[0120] During the expansion of hydraulic fluid chamber **186b**, there will be a corresponding contraction of hydraulic fluid chamber **186a** of hydraulic cylinder **152a**. This results in hydraulic fluid being driven out of hydraulic fluid chamber **186a** through port **1184a** and into and along fluid communication line **1166a**. The configuration of shuttle valve device **1168** will be such that on what is now a relatively low pressure side, hydraulic fluid can now flow into port V and out of port Q of shuttle valve device **1168**, then along fluid communication line **1163a** to port S of pump unit **1174**. However, the relief valve associated with shuttle valve device **1168** may in this operational configuration, direct a small portion of the hydraulic fluid flowing along line **1166a** to port M for communication to reservoir **1172**, as discussed above. Again most of the hydraulic fluid flowing in communication line **1166a** will be directed to communication line **1163a** for return to pump unit **1174** at port S but a small portion (e.g. 1%) may be directed by shuttle valve device **1168** to port M for communication to reservoir **1172**, as discussed above. However, most (e.g. about 99%) of the hydraulic fluid flowing in communication line **1166a** will be directed to communication line **1163a** for return to pump unit **1174** and enter at port S.

[0121] The foregoing describes one cycle which can be repeated continuously for multiple cycles, as may be required during operation of gas compressor system **126**. If a change in flow rate/fluid pressure is required in hydraulic fluid supply system **1160**, to change the speed of movement and increase the frequency of the cycles, controller **200** may send an appropriate signal to prime mover **1175** to vary the output to vary the rotational speed of shaft **1173**. Alternately and/or additionally, controller **200** may send a displacement control signal to the input of pump unit **1174** to drive the solenoid (not shown) to cause a different angle α of the

swashplate to provide different flow rate conditions at the port P and no flow at outlet S or to provide different flow rate conditions at the port S and no flow at outlet P. If zero flow is required, the swash plate may be moved to an angle of zero degrees.

[0122] Controller **200** may also include an input for receiving a start signal operable to cause the controller **200** to start operation of gas compressor system **126** and outputs for producing a control signal for controlling operation of the prime mover **1175** and pump unit **1174**. The start signal may be provided by a start button within an enclosure that is depressed by an operator on site to commence operation. Alternatively, the start signal may be received from a remotely located controller, which may be communication with the controller via a wireless or wired connection. The controller **200** may be implemented using a microcontroller circuit although in other embodiments, the controller may be implemented as an application specific integrated circuit (ASIC) or other integrated circuit, a digital signal processor, an analog controller, a hardwired electronic or logic circuit, or using a programmable logic device or gate array, for example.

[0123] With reference now to FIG. 4, it may be appreciated that hydraulic cylinder barrel **187a** may be divided into three zones: (i) a zone ZH dedicated exclusively to holding hydraulic fluid; (ii) a zone ZB dedicated exclusively for the buffer area and (iii) an overlap zone, Z_o , that which, depending upon where the hydraulic piston **154a** is in the stroke cycle, will vary between an area holding hydraulic fluid and an area providing part of the buffer chamber. Hydraulic cylinder barrel **187b** may be divided into a corresponding set of three zones in the same manner with reference to the movement of hydraulic piston **154b**.

[0124] If the length X_{Ba} (which is the length of the cylinder barrel from gas cylinder head **192a** to the inward facing surface of hydraulic cylinder **154a** at its full right position) is greater than the stroke length X_s , then any point **P1a** on piston rod **194** on the piston rod **194** that is at least for part of the stroke within gas compression chamber section **181a**, will not move beyond the distance X_{Ba} when the gas piston **182** and the hydraulic cylinder **154a** move from the farthestmost right positions of the stroke position (1) to the farthestmost left positions of the stroke position (2). Thus, any materials/contaminants carried on piston rod **194** starting at **P1a** will not move beyond the area of the hydraulic cylinder barrel **187a** that is dedicated to providing buffer chamber **195a**. Thus, any such contaminants traveling on piston rod **194** will be prevented, or at least inhibited, from moving into the zones ZH and Z_o of hydraulic cylinder barrel **187a** that hold hydraulic fluid. Thus any point **P1a** on piston rod **194** that passes into the gas compression chamber will not pass into an area of the hydraulic cylinder barrel **187a** that will encounter hydraulic fluid (i.e. It will not pass into ZH or Z_o). Thus, all portions of piston rod **194** that encounter gas, will not be exposed to an area that is directly exposed to hydraulic fluid. Thus cross contamination of contaminants that may be present with the natural gas in the gas compression cylinder **180** may be prevented or inhibited from migrating into the hydraulic fluid that is in that areas of hydraulic cylinder barrel **187a** adapted for holding hydraulic fluid. It may be appreciated, that since there is an overlap zone, the hydraulic pistons do move from a zone where there should never be anything but hydraulic fluid to a zone which transitions between hydraulic fluid and the

contents (e.g. air) of the buffer zone. Therefore, contaminants on the inner surface wall of the cylinder barrel **187a**, **187b** in the overlap zone could theoretically get transferred to the edge surface of the piston. However, the presence of buffer zone significantly reduces the level of risk of cross contamination of contaminants into the hydraulic fluid.

[0125] With reference continuing to FIG. 4, it may be appreciated that hydraulic cylinder barrel **187b** may also be divided into three zones—like hydraulic cylinder barrel **187a**, namely: (i) a zone ZH dedicated exclusively to holding hydraulic fluid; (ii) a zone ZB dedicated exclusively for the buffer area and (iii) an overlap zone that which, depending upon where the device is in the stroke cycle, will vary between an area holding hydraulic fluid and an area providing part of the buffer chamber.

[0126] If the length XBb (which is the length of the cylinder barrel from gas cylinder head **192b** to the inward facing surface of hydraulic cylinder **152b** at its full right position) is greater than the stroke length Xs, then any point P1b on piston rod **194** will not move beyond the distance XBb when the gas piston **182** and the hydraulic cylinder **154b** move from the farthestmost right positions of the stroke (1) to the farthestmost left positions of the stroke (2). Thus any materials/contaminants on piston rod **194** starting at P1b will be prevented or at least inhibited from moving beyond the area of the hydraulic cylinder barrel **187b** that provides buffer chamber **195b**. Thus, any such contaminants travelling on piston rod **194** will be prevented, or at least inhibited, from moving into the zones ZH and Zo of hydraulic cylinder barrel **187b** that hold hydraulic fluid. Thus any point P2b on piston rod **194** that passes into the gas compression chamber will not pass into an area of the hydraulic cylinder barrel **187b** that will encounter hydraulic fluid (i.e. It will not pass into Zh or Zo). Thus, all portions of piston rod **194** that encounter gas, will not be exposed to an area that is directly exposed to hydraulic fluid. Thus cross contamination of contaminants that may be present with the natural gas in the gas compression cylinder **180** may be prevented or inhibited from migrating into the hydraulic fluid that is in that area of hydraulic cylinder barrel **187b** adapted for holding hydraulic fluid. Thus, any such contaminants travelling on piston rod **194** will be prevented or at least inhibited from moving into the area of hydraulic cylinder barrel **187b** that in operation, holds hydraulic fluid. Thus cross contamination of contaminants that may be present with the natural gas in the gas compression cylinder **180** may be prevented or at least inhibited from migrating into the hydraulic fluid that is in that area of hydraulic cylinder barrel **187b** that is used to hold hydraulic fluid.

[0127] In some embodiments, during operation of hydraulic gas compressor **150**, buffer chambers **195a**, **195b** may each be separately open to ambient air, such that air within buffer chamber may be exchanged with the external environment (e.g. air at ambient pressure and temperature). However, it may not be desirable for the air in buffer chambers **195a**, **195b** to be discharged into the environment and possibly other components to be discharged directly into the environment, due to the potential for other components that are not environmentally friendly also being present with the air. Thus a closed system may be highly undesirable such that for example buffer chambers **195a**, **195b** may be in communication with each such that a substantially constant amount of gas (e.g. such as air) can be shuttled back and

forth through communication lines—such as communication lines **215a**, **215b** in FIG. 7.

[0128] Buffer chambers **195a** and/or **195b** may in some embodiments be adapted to function as a purge region. For example, buffer chambers **195a**, **195b** may be fluidly interconnected to each other, and may also in some embodiments, be in fluid communication with a common pressurized gas regulator system **214** (FIG. 7), through gas lines **215a**, **215b** respectively. Pressurized gas regulator system **214** may for example maintain a gas at a desired gas pressure within buffer chambers **195a**, **195b** that is always above the pressure of the compressed natural gas and/or other gases that are communicated into and compressed in gas compression cylinder chamber sections **181a**, **181b** respectively. For example, pressurized gas regulator system **214** may provide a buffer gas such as purified natural gas, air, or purified nitrogen gas, or another inert gas, within buffer chambers **195a**, **195b**. This may then prevent or substantially restrict natural gas and any contaminants contained in gas compression cylinder sections **181a**, **181b** migrating into buffer chambers **195a**, **195b**. The high pressure buffer gas in buffer chambers **195a**, **195b** may prevent movement of natural gas and possibly contaminants into the buffer chambers **195a**, **195b**. Furthermore if the buffer gas is inert, any gas that seeps into the gas compression cylinder chamber sections **181a**, **181b** will not react with the natural gas and/or contaminants. This can be particularly beneficial if for example the contaminants include hydrogen sulphide gas which may be present in one or both of gas compression cylinder chamber sections **181a**, **181b**.

[0129] In some embodiments, gas lines **215a**, **215b** (FIG. 7) may not be in fluid communication with a pressurized gas regulator system **214**—but instead may be interconnected directly with each other to provide a substantially unobstructed communication channel for whatever gas is in buffer chambers **195a**, **195b**. Thus during operation of gas compressor **150**, as hydraulic pistons **154a**, **154b** move right and then left (and/or upwards downwards) in unison, as one buffer chamber (e.g. buffer chamber **195a**) increases in size, the other buffer chamber (e.g. buffer chamber **195b**) will decrease in size. So instead of gas in each buffer chamber **195a**, **195b** being alternately compressed and then decompressed, a fixed total volume of gas at a substantially constant pressure may permit gas thereof to shuttle between the buffer chambers **195a**, **195b** in a buffer chamber circuit.

[0130] Also, instead of being directly connected with each other, buffer chambers **195a**, **195b** may be both in communication with a common holding tank **1214** (FIG. 7) that may provide a source of gas that may be communicated between buffer chambers **195a**, **195b**. The gas in the buffer chamber gas circuit may be at ambient pressure in some embodiments and pressurized in other embodiments. The holding tank **1214** may in some embodiments also serve as a separation tank whereby any liquids being transferred with the gas in the buffer chamber system can be drained off.

[0131] In the embodiment of FIGS. 2, and 9A-9C, a drainage port **207a** for buffer chamber **195a** may be provided on an underside surface of hydraulic cylinder barrel **187a**. A corresponding drainage port **207b** may be provided for buffer chamber **195b**. Drainage ports **207a**, **207b** may allow drainage of any liquids that may have accumulated in each of buffer chambers **195a**, **195b** respectively. Alternately or additionally such liquids may be able to be drained from an outlet in a holding tank **1214**.

[0132] As illustrated in FIGS. 5 and 6, gas compressor system 126 may include a cabinet enclosure 1290 for holding components of hydraulic fluid supply system 1160 including pump unit 1174, prime mover 1175, reservoir 1172, shuttle device 1168, filters 1182 and 1171, thermal valve device 1142 and cooler 1143. Controller 200 may also be held in cabinet enclosure 1290. One or more electrical cables 1291 may be provided to provide power and communication pathways with the components of gas compressor system 126 that are mounted on a support frame 1292. Additionally, piping 124 (FIG. 1) carrying natural gas to compressor 150 may be connected to connector 250 when gas compressor 150 is mounted on support frame 1292 to provide a supply of natural gas to gas compressor 150.

[0133] Gas compressor system 126 may thus also include a support frame 1292. Support frame 1292 may be generally configured to support gas compressor 150 in a generally horizontal orientation. Support frame 1292 may include a longitudinally extending hollow tubular beam member 1295 which may be made from any suitable material such as steel or aluminium. Beam member 1295 may be supported proximate each longitudinal end by pairs of support legs 1293a, 1293b which may be attached to beam member 1295 such as by welding. Pairs of support legs 1293a, 1293b may be transversely braced by transversely braced support members 1294a, 1294b respectively that are attached thereto such as by welding. Support legs 1293a, 1293b and brace members 1294a, 1294b may also be made from any suitable material such as steel or aluminium.

[0134] Mounted to an upper surface of beam member 1295 may be L-shaped, transversely oriented support brackets 1298a, 1298b that may be appropriately longitudinally spaced from each other (see also FIGS. 8 to 9C). Support brackets 1298a, 1298b may be secured to beam member 1295 by U-members 1299a, 1299b respectively that are secured around the outer surface of beam member 1295 and then secured to support brackets 1298a, 1298b by passing threaded ends through openings 1300a, 1300b and securing the ends with pairs of nuts 1303a, 1303b (FIG. 6). Support bracket 1298a may be secured to gas cylinder head plate 212a by bolts 1302 received through aligned openings in support bracket 1298a and gas cylinder head plate 212a, secured by nuts 1301. Similarly, support bracket 1298b may be secured to gas cylinder head plate 212b by bolts 1302 received through aligned openings in support bracket 1298b and gas cylinder head plate 212, secured by nuts 1301. In this way, gas compressor 150 may be securely mounted to and supported by support frame 1292.

[0135] Hydraulic fluid communication lines 1166a, 1166b extend from ports 184a, 184b respectively to opposite ends of support frame 1294 and may extend under a lower surface of beam member 1295 to a common central location where they may then extend together to enclosure cabinet 1290 housing shuttle valve device 1168.

[0136] Tubular beam member 1295 may be hollow and may be configured to act as, or to hold a separate tank such as, holding tank 1214. Thus beam member 1285 may serve to act as a gas/liquid separation and holding tank and may serve to provide a gas reservoir for gas for buffer chamber system of buffer chambers 195a, 195b. Lines 215a, 215b may lead from ports of buffer chambers 195a, 195b into ports 1305a, 1305b into holding tank 1214 within tubular member 1295.

[0137] Holding tank 1214 within beam member 1295 may also have an externally accessible tank vent 1296 that allow for gas in holding tank 1214 to be vented out. Also, holding tank 1214 may have a manual drain device 1297 that is also externally accessible and may be manually operable by an operator to permit liquids that may accumulate in holding tank 1214 to be removed.

[0138] In operation of gas compressor system 126, including hydraulic gas compressor 150, the reciprocal movement of the hydraulic pistons 152a, 152b, can be driven by a hydraulic fluid supply system such as for example hydraulic fluid supply system 1160 as described above. The reciprocal movement of hydraulic pistons 154a, 154b will cause the size of the buffer chambers 195a, 195b to grow smaller and larger, with the change in size of the two buffer chambers 195a, 195b being for example 180 degrees out of phase with each other. Thus, as hydraulic piston 154b moves from position 1 to position 2 in FIG. 6 driven by hydraulic fluid forced into hydraulic fluid chamber 186b, some of the gas (e.g. air) in buffer chamber 195b will be forced into gas line(s) 215a, 215b (FIG. 7) that interconnect chambers 195a, 195b, and flow through holding tank 1214 towards and into buffer chamber 195a. In the reverse direction, as hydraulic piston 154a moves from position 2 to position 1 in FIG. 4 driven by hydraulic fluid forced into hydraulic fluid chamber 186a, some of the gas (e.g. air) in buffer chamber 195a will be forced into gas lines 215a, 215b and flow through holding tank 1214 towards and into buffer chamber 195b. In this way, the gas in the system of buffer chambers 195a, 195b can be part of a closed loop system, and gas may simply shuttle between the two buffer chambers 195a, 195b, (and optionally through holding tank 1214) thus preventing contaminants that may move into buffer chambers 195a, 195b from gas cylinder sections 181a, 181b respectively, from contaminating the outside environment. Additionally, such a closed loop system can prevent any contaminants in the outside environment from entering the buffer chambers 195a, 195b and thus potentially migrating into the hydraulic fluid chambers 186a, 186b respectively.

[0139] Gas compressor system 126 may also include a natural gas communication system to allow natural gas to be delivered from piping 124 (FIG. 1) to the two gas compression chamber sections 181a, 181b of gas compression cylinder 180 of gas compressor 150, and then communicate the compressed natural gas from the sections 181a, 181b to piping 130 for delivery to oil and gas flow line 133.

[0140] With reference to FIG. 2 in particular, the natural gas communication system may include a first input valve and connector device 250, a second input valve and connector device 260, a first output valve and connector device 261 and a second output valve and connector device 251. A gas input suction distribution line 204 fluidly interconnects input valve and connector device 250 with input valve and connector device 260. A gas output pressure distribution line 209 fluidly interconnects output valve and connector device 261 with valve and connector device 251.

[0141] With reference also to FIGS. 8, 8A and 8B, input valve and connector device 250 may include a gas compression chamber section valve and connector, a gas pipe input connector, and a gas suction distribution line connector. In an embodiment as shown in FIGS. 2 and 3(i) to (iv) an excess pressure valve and bypass connector is also provided. In an alternate embodiment as shown in FIGS. 8 to 9C, there is no bypass connector. However, in this latter embodiment

there is a lubrication connector **1255** to which is attached in series to an input port of a lubrication device **1256** comprising suitable fittings and valves. Lubrication device **1256** allows a lubricant such as a lubricating oil (like WD-40 oil) to be injected into the passageway where the natural gas passes through connector device **250**. The WD40 can be used to dissolve hydrocarbon sludges and soots to keep seals functional.

[0142] An electronic gas pressure sensing/transducer device **1257** may also be provided which may for example be a model AST46HAP00300PGTIL000 made by American Sensor technologies. This sensor reads the casing gas pressure.

[0143] Gas pressure sensing device/transducer **1257** may be in electronic communication with controller **200** and may provide signals to controller **200** indicative of the pressure of the gas in the casing/gas distribution line **204**. In response to such signal, controller **200** may modify the operation of system **100** and in particular the operation of hydraulic fluid supply system **1160**. For example, if the pressure in gas suction distribution line **204** descends to a first threshold level (e.g. 8 psi), controller **200** can control the operation of hydraulic fluid supply system **170** to slow down the reciprocating motion of gas compressor **150**, which should allow the pressure of the gas that is being fed to connector device **250** and gas suction distribution line **204** to increase. If the pressure measured by sensing device **1257** reaches a second lower threshold—such that it may be getting close to zero or negative pressure (e.g. 3 psi) controller **200** may cause hydraulic fluid supply system **1160** to cease the operation of gas compressor **150**.

[0144] Hydraulic fluid supply system **1160** may then be re-started by controller **200**, if and when the pressure measured by gas pressure sensing device/transducer **1257** again rises to an acceptable threshold level as detected by a signal received by controller **200**.

[0145] The output port of gas pressure sensing device **1257** may be connected to an input connector of gas suction distribution line **204**.

[0146] With reference to FIGS. **8A** and **8B**, output valve and connector device **251** may include a gas compression chamber section valve, gas pipe output connector **205** and a gas pressure distribution line connector **263**. In an embodiment as shown in FIG. **2**, an excess pressure valve and bypass connector is also provided. In an alternate embodiment as shown in FIGS. **8** to **9C**, there is no bypass connector.

[0147] With reference to the embodiment of FIGS. **2** and **3(i)** to **3(iv)**, a pressure relief valve **265** is provided limit the gas discharge pressure. In some embodiments, relief valve **265** may discharge pressurized gas to the environment. However, in this illustrated embodiment, the relieved gas can be sent back through a bypass hose **266** to the suction side of the gas compressor **150** to limit environmental discharge. One end of a bypass hose **266** may be connected for communication of natural gas from a port of an excess gas pressure bypass valve **265** (FIG. **2**). The opposite end of bypass port may be connected to an input port of connector **250**. The output port from bypass valve **265** may provide one way fluid communication through bypass hose **266** of excessively pressured gas in for example gas output distribution line **209**, to connector **250** and back to the gas input side of gas compressor **150**. Thus, once the pressure is reduced to a

level that is suitable for transmission in piping **120** (FIG. **2A**), gas pressure relief valve will close.

[0148] With reference to FIGS. **8** and **8B**, installed within connector **250** is a one way check valve device **1250**. When connector **250** is received in an opening **1270** on the inward seal side of casing **201a**, gas may flow through connector **250** and its check valve device **1250**, through casing **201a** into gas compression chamber section **181a**. Similarly within connector **251** is a one way check valve device **1251**. When connector **262** is received in an opening **1271** on the inward seal side of casing **201b**, gas may flow out of gas compression chamber section **181a** through casing **201a**, and then through one-way valve device **1251** of connector **251** where gas can then flow through output connector **205** (FIG. **2**) into piping **130** (FIG. **1**).

[0149] The check valve device **1250** associated with connector **250** is operable to allow gas to flow into casing **201a** and gas compression chamber section **181a**, if the gas pressure at connector **250** is higher than the gas pressure on the inward side of the check valve device **1250**. This will occur for example when gas compression chamber section **181a** is undergoing expansion in size as gas piston **182** moves away from head assembly **200a** resulting in a drop in pressure within compression chamber section **181a**. Check valve device **1251** is operable to allow gas to flow out of casing **201a** and gas compression chamber section **181a**, if the gas pressure in gas compression chamber section **181a** and casing **201a** is higher than the gas pressure on the outward side of check valve device **1251** of connector **251**, and when the gas pressure reaches a certain minimum threshold pressure that allows it to open. The check valve device **1251** may be operable to be adjusted to set the threshold opening pressure difference that causes/allows the one way valve to open. The increase in pressure gas compression chamber section **181a** and casing **201a** will occur for example when gas compression chamber section **181a** is undergoing reduction in size as gas piston **182** moves towards from head assembly **200a** resulting in an increase in pressure within compression chamber section **181a**.

[0150] With reference to FIG. **8**, at the opposite end of gas suction distribution line **204** to the end connected to gas pressure sensing device **1257**, is a second input connector **260**. Installed within connector **260** is a one way check valve device **1260**. When connector **260** is received in an opening on the inward seal side of casing **201b**, gas may flow from gas distribution line **204** through connector **260** and valve device **1260**, through casing **201b** into gas compression chamber section **181b**.

[0151] Similarly at the opposite end of gas pressure distribution line **209** to the end connected to connector **210**, is an output connector **261**. Installed within connector **261** is a one way check valve device **1261**. When connector **261** is received in an opening on the inward seal side of casing **201b**, gas may flow out of gas compression chamber section **181b** through casing **201b** and then through valve device **1261** and connector **261** where pressurized gas can then flow through gas pressure distribution line **209** to output connector **205** and into piping **130** (FIG. **1**).

[0152] One way check valve device **1260** is operable to allow gas to flow into casing **201b** and gas compression chamber section **181b**, if the gas pressure at connector **260** is higher than the gas pressure on the inward side of check valve device **1260**. This will occur for example when gas compression chamber section **181b** is undergoing expansion

in size as gas piston **182** moves away from head assembly **200b** resulting in a drop in pressure within compression chamber section **181b**. One way check valve device **1261** is operable to allow gas to flow out of casing **201b** and gas compression chamber section **181b**, if the gas pressure in gas compression chamber section **181b** and casing **201b** is higher than the gas pressure on the outward side of check valve device **1261** of connector **261**, and when the gas pressure reaches a certain minimum threshold pressure that allows it to open. The check valve device **1261** may be operable to be adjusted to set the threshold opening pressure difference that causes/allows the one way valve to open. The increase in pressure gas compression chamber section **181b** and casing **201b** will occur for example when gas compression chamber section **181b** is undergoing reduction in size as gas piston **182** moves towards from head assembly **200b** resulting in an increase in pressure within compression chamber section **181b**.

[0153] With particular reference to FIG. 8B, interposed between an output end of gas pressure distribution line **209** and valve and connector **251** may be a bypass valve **1265**. If the gas pressure in gas pressure distribution line **209** and/or in connector **250**, reaches or exceeds a pre-determined upper pressure threshold level, excess pressure valve **1265** will open to relieve the pressure and reduce the pressure to a level that is suitable for transmission into piping **130** (FIG. 1).

[0154] In operation of gas compressor **150**, hydraulic pistons **154a**, **154b** may be driven in reciprocating longitudinal movement for example by hydraulic fluid supply system **1160** as described above, thus driving gas piston **182** as well. The following describes the operation of the gas flow and gas compression in gas compressor system **126**.

[0155] With hydraulic pistons **154a**, **154b** and gas piston **182** in the positions shown in FIG. 3(i) natural gas will be already located in gas cylinder compression section **181a**, having been previously drawn into gas cylinder compression section **181a** during the previous stroke due to pressure the differential that develops between the outer side of one way valve device **1250** and the inner side of valve device **1250** as piston **182** moved from left to right. During that previous stroke, natural gas will have been drawn from pipe **124** through connector **202** and connector device **250** and its check valve device **1250** into gas compression chamber section **181a**, with check valve **1251** of connector device **251** being closed due to the pressure differential between the inner side of check valve device **1251** and the outer side of check valve device **1251** thus allowing gas compression cylinder section **181a** to be filled with natural gas at a lower pressure than the gas on the outside of connector device **251**.

[0156] Thus, with the pistons in the positions shown in FIG. 3(i), hydraulic cylinder chamber **186b** is supplied with pressurized hydraulic fluid in a manner such as is described above, thus driving hydraulic piston **154b**, along with piston rod **194**, gas piston **182** and hydraulic piston **154a** attached to piston rod **194**, from the position shown in FIG. 3(i) to the position shown in FIG. 3(ii). As this is occurring, hydraulic fluid in hydraulic cylinder chamber **186a** will be forced out of chamber **186a**, and flow as described above.

[0157] As hydraulic piston **154b**, along with piston rod **194**, gas piston **182** and hydraulic piston **154a** attached to piston rod **194**, move from the position shown in FIG. 3(i) to the position shown in FIG. 3(ii), natural gas will be drawn from supply line **124**, through connector device **250** into gas

suction distribution line **204**, and then pass through input valve connector **260** and one way valve device **1260** and into gas compression section **181b**. Natural gas will flow in such a manner because as gas piston **182** moves to the left as shown in FIGS. 3(i) to (ii), the pressure in gas compression chamber **181b** will drop, which will create a suction that will cause the natural gas in pipe **124** to flow.

[0158] Simultaneously, the movement of gas piston **182** to the left will compress the natural gas that is already present in gas compression chamber section **181a**. As the pressure rises in gas chamber section **181a**, gas flowing into connector **250** from pipe **124** will not enter chamber section **181a**. Additionally, gas being compressed in gas compression chamber section **181a** will stay in gas compression chamber section **181a** until the pressure therein reaches the threshold level of gas pressure that is provided by one way check valve device **1251**. Gas being compressed in chamber section **181a** can't flow out of chamber section **181a** into connector **250** because of the orientation of check valve device **1250**.

[0159] The foregoing movement and compression of natural gas and movement of hydraulic fluid will continue as the pistons continue to move from the positions shown in FIG. 3(ii) to the position shown in FIG. 3(iii). During that time, dependent upon the pressure in gas compression chamber section **181a**, gas will be allowed to pass out of gas compression chamber section **181a** through connector **251** and will pass into piping **130** once the pressure is high enough to activate one way valve device **1251**.

[0160] Just before hydraulic piston **154b** reaches the position shown in FIG. 3(iii), proximity sensor **157b** will detect the presence of hydraulic piston **154b** within hydraulic cylinder **152b** at a longitudinal position that is a short distance before the end of the stroke within hydraulic cylinder **152b**. Proximity sensor **157b** will then send a signal to controller **200**, in response to which controller **200** will change the operational configuration of hydraulic fluid supply system **1160**, as described above. This will result in hydraulic piston **154b** not being driven any further to the left in hydraulic cylinder **152b** than the position shown in FIG. 3(iii).

[0161] Once hydraulic piston **154b**, along with piston rod **194**, gas piston **182** and hydraulic piston **154a** attached to piston rod **194**, are in the position shown in FIG. 3(iii), natural gas will have been drawn through connector **260** and one way valve device **1260** again due to the pressure differential that is developed between gas compression chamber section **181b** and gas suction distribution pipe **204**, so that gas compression chamber section **181b** is filled with natural gas. Much of the gas in gas compression chamber **181a** that has been compressed by the movement of gas piston **182** from the position shown in FIG. 3(i) to the position shown in FIG. 3(iii), will, once compressed sufficiently to exceed the threshold level of valve device **1251**, have exited gas compression chamber **181a** and pass from gas pipeline output connector **205** into piping **130** (FIG. 1) for delivery to oil and gas pipeline **133**. If the gas pressure is too high to be received in piping **130**, excess valve and bypass connector **265/1265** will be opened to allow excess gas to exit to reduce the pressure.

[0162] Next, gas compressor system **126**, including hydraulic fluid supply system **1160** is reconfigured for the return drive stroke. As natural gas has been drawn into gas compression cylinder section **181b** it is ready to be compressed by gas piston **182**. With hydraulic pistons **154a**,

154b and gas piston **182** in the positions shown in FIG. 3(iii), hydraulic cylinder chamber **186a** is supplied with pressurized hydraulic fluid by hydraulic fluid supply system **1160** for example as described above. This movement drives hydraulic piston **154a**, along with piston rod **194**, gas piston **182** and hydraulic piston **154a** attached to piston rod **194**, from the position shown in FIG. 3(iii) to the position shown in FIG. 3(iv). As this is occurring, hydraulic fluid in hydraulic cylinder chamber **186b** will be forced out of the hydraulic fluid chamber **186a** and may be handled by hydraulic fluid supply system **1160** as described above.

[0163] As hydraulic piston **154a**, along with piston rod **194**, gas piston **182** and hydraulic piston **154b** attached to piston rod **194**, move from the position shown in FIG. 3(iii) to the position shown in FIG. 3(iv), natural gas will be drawn from supply line **124**, through connector **253** of valve and connector device **250** into gas compression section **181a** due the drop in pressure of gas in gas compression section **181a**, relative to the gas pressure in supply line **124** and the outside of connector **250**. Simultaneously, the movement of gas piston **182** will compress the natural gas that is already present in gas compression section **181b**. As the gas in gas compression chamber **181b** is being compressed by the movement of gas piston **182**, once the gas pressure reaches the threshold level of valve device **1261** to be activated, gas will be able to exit gas compression chamber **181b** and pass through connector **261**, into gas pressure distribution line **209** and then pass through output connector **205** into piping **130** (FIG. 3) for delivery to oil and gas pipeline **133**. Again, if the gas pressure is too high to be received in piping **130**, excess valve and bypass connector **265/1265** will be opened to allow excess gas to exit to reduce the gas pressure in gas pressure distribution line **209** and piping **130**.

[0164] The foregoing movement and compression of natural gas and hydraulic fluid will continue as the pistons continue to move from the positions shown in FIG. 3(iv) to return to the position shown in FIG. 3(i). Just before piston **154a** reaches the position shown in FIG. 3(i), proximity sensor **157a** will detect the presence of hydraulic piston **154a** within hydraulic cylinder **152a** at a longitudinal position that is shortly before the end of the stroke within hydraulic cylinder **152a**. Proximity sensor **157a** will then send a signal to controller **200**, in response to which controller **200** will reconfigure the operational mode of hydraulic fluid supply system **1160** as described above. This will result in hydraulic piston **154a** not be driven any further to the right than the position shown in FIG. 3(i).

[0165] Once hydraulic piston **154a**, along with piston rod **194**, gas piston **182** and hydraulic piston **154b** attached to piston rod **194**, are in the position shown in FIG. 3(i), natural gas will have been drawn through valve and connector **253** so that gas compression chamber section **181a** is once again filled and controller **200** will send a signal to the hydraulic fluid supply system **1160** so that gas compressor system **126** is ready to commence another cycle of operation.

[0166] During the operation of the gas compressor **150** as described above, any contaminants that may be carried with the natural gas from supply pipe **124** will enter into gas compression chamber sections **181a**, **181b**. However, the components of seal devices **198a**, **198b** associated with casings **201a**, **201b**, as described above, will provide a barrier preventing, or at least significantly limiting, the migration of any contaminants out of gas compression chamber sections **181a**, **181b**. However, any contaminants

that do pass seal devices **198a**, **198b** are likely to be held in respective buffer chambers **195a**, **195b** and in combination with seal devices **196a**, **196b** of hydraulic pistons **154a**, **154b** respectively, may prevent contaminants from entering into the respective hydraulic cylinder chambers **186a**, **186b**. Particularly if buffer chambers **195a**, **195b** are pressurized, such as with pressurized air or a pressurized inert gas, then this should greatly restrict or inhibit the movement of contaminants in the natural gas in gas compression chamber sections **181a**, **181b** from migrating into buffer chambers **195a**, **195b**, thus further protecting the hydraulic fluid in hydraulic cylinder chambers **186a**, **186b**.

[0167] It should be noted that in use, hydraulic gas compressor **150** may be oriented generally horizontally, generally vertically, or at an angle to both vertical and horizontal directions.

[0168] While the gas compressor system **126** that is illustrated in FIGS. 1 to 9C discloses a single buffer chamber **195a**, **195b** on each side of the gas compressor **150** between the gas compression cylinder **180** and the hydraulic fluid chambers **186a**, **186b**, in other embodiments more than one buffer chamber may be configured on one or both sides of gas compression cylinder **180**. Also, the buffer cavities may be pressurized with an inert gas to a pressure that is always greater than the pressure of the gas in the gas compression chambers so that if there is any gas leakage through the gas piston rod seals, that leakage is directed from the buffer chamber(s) toward the gas compression chamber(s) and not in the opposite direction. This may ensure that no dangerous gases such as hydrogen sulfide (H₂S) are leaked from the gas compressor system.

Adaptive Control System for Hydraulic Gas Compressor

[0169] As one skilled in the art will appreciate, it is desirable to provide efficient gas compression when operating a gas compressor as disclosed herein. Ideally, the maximum gas compression can be achieved if the gas piston in the gas compression chamber, such as gas piston **182** in gas compressor **150**, is driven to reach and contact the end of the gas compression chamber at the end of each stroke. In fact, in some conventional hydraulic gas compression systems, the gas piston is driven in each direction until a face of the gas piston hits an end of the gas compression chamber (referred to as “physical end of stroke”) before the hydraulic driving pressure is reversed in direction to drive the gas piston in the opposite direction. However, the impact of the physical contact between the faces of the gas piston and the ends of the gas compression chamber can produce loud noises and cause wear and tear of components in the gas compressor, thus reducing their useful lifetime.

[0170] To avoid such impact, in some existing gas compressing systems, the hydraulic pump used to apply hydraulic pressure on the gas piston is controlled to reverse the direction of the applied pressure before the gas piston contacts each end of the gas compressor chamber, based on, for example, the measured position and speed of the gas piston. However, as it is difficult to predict precisely when the piston will hit the physical end of stroke, many systems overcompensate by reversing the applied driving pressure when the piston is still a large distance away from the physical end. As a result, the gas compression efficiency is significantly reduced. Some techniques exist to provide more precise measurement of the piston position and speed but such techniques typically require expensive sensing and

control equipment, and the sensors used also take up large physical space. For example, in some existing systems full length position sensors are used along the entire length of the gas compressor in order to determine the position of the piston during the entire stroke length in real time, so that the transition between strokes can be controlled to avoid physical end of stroke. However, such a technique requires precise and fast position detection along the full-length of the cylinder and suitable sensors for such detection can be expensive, and with the added sensors and related equipment the gas compressor can become bulky.

[0171] It has been recognized that an adaptive control method based on detected speed of the gas piston, the temperature of the hydraulic driving fluid, and the load pressure applied on the piston at certain piston position can provide effective control of the movement of the gas piston using relatively inexpensive proximity sensors, temperature sensors and pressure sensors.

[0172] In an embodiment, the adaptive control may be implemented as illustrated in FIG. 10A for controlling a gas compressor 150' which is modified from gas compressor 150 as explained below.

[0173] A hydraulic fluid supply system 1160', which may be similar to the supply system 1160, is provided to supply a hydraulic driving fluid for applying a driving force on gas piston 182.

[0174] As discussed with reference to gas compressor 150, the driving force (or pressure) is cyclically reversed between left and right directions in the view as illustrated in FIG. 10A to cause gas piston 182 to reciprocate in strokes. As in gas compressor 150, two proximity sensors 157a and 157b are provided and positioned to provide timing and position signals for monitoring the position and speed of travel of gas piston 182 during each stroke. For example, proximity sensor 157b may be positioned to detect whether gas piston 182 is at or near a predefined end of stroke position on the left hand side, near chamber end 1008, as shown in FIG. 10A (this position is referred to as "Position 1" for ease of reference), and proximity sensor 157a may be positioned to detect whether gas piston 182 is at or near a predefined end of stroke position on the right hand side (this position is referred to as "Position 2"), near chamber end 1010. In some embodiments, gas compressor 150 and proximity sensors 157a and 157b may be configured so that proximity sensor 157b is in an "on" state when gas piston 182 is at or near Position 1, and is in an "off" state when gas piston 182 is not at or near Position 1; and proximity sensor 157a is in an "on" state when gas piston 182 is at or near Position 2, and is in an "off" state when gas piston 182 is not at or near Position 2.

[0175] As in system 1160, a pressure sensor 1004 may be provided at each of ports P and S respectively and the pressure sensors 1004 are used to detect the fluid pressures applied by the pump unit 1174 to the respective hydraulic pistons 154a, 154b, which can be used to calculate the load pressure applied on gas piston 182.

[0176] In addition, a temperature sensor 1006 is also provided for controlling the pump unit 1174 in system 1160'. The temperature sensor 1006 is positioned and configured to detect the temperature of the hydraulic driving fluid in the hydraulic fluid chambers 186a, 186b. The temperature sensor 1006 may be placed at any suitable location along the hydraulic fluid loop. For example, in an embodiment, the temperature sensor 1006 may be positioned at a fluid port.

[0177] Controller 200' may include hardware and software as discussed earlier, including hardware and software configured to receive and process signals from proximity sensors 157a, 157b and for controlling the operation of pump unit 1174, but is modified to also receive signals from pressure sensors 1004 and temperature sensor 1006 and processing these signals, and the signals from the proximity sensors 157a, 157b for controlling the pump unit 1174.

[0178] Optionally, end-of-stroke indicators 1002a, 1002b may be provided and positioned relative to the respective hydraulic fluid chambers 186a, 186b to provide signals to controller 200' when the terminal ends of hydraulic pistons 154a, 154b reach preselected positions which are referred to as the "pre-defined end of stroke position" in the respective stroke direction. The pre-defined end of stroke positions are selected such that when the corresponding terminal end of the corresponding hydraulic piston 154a, 154b is at the corresponding pre-defined end of stroke position, the gas piston is almost at the physical end of stroke but is not yet in contact with the corresponding chamber wall in the gas chamber. For example, in an embodiment, a pre-defined end of stroke position may be 0.5" away from a terminal end wall of the hydraulic fluid chamber 186a, 186b. When end-of-stroke indicators 1002a, 1002b are provided, controller 200' is configured to receive signals from the end-of-stroke indicators 1002a, 1002b and process these signals to determine whether an end of stroke has been reached during each stroke.

[0179] During operation, controller 200' receives signals from the proximity sensors 157a, 157b, pressure sensor(s) 1004, temperature sensor 1006, and optionally end of stroke indicators 1002a, 1002b, during each stroke. Controller 200' then determines a time interval for operating pump unit 1174 to pump in a reversed direction based on the received signal, or determines a next reversal time T_r for reversing the pumping direction. Controller 200' controls pump unit 1174 to reverse the pump's pumping direction at the determined time T_r , for the determined time interval, which is referred to as the "lag time" (LP) for each pump cycle.

[0180] It may be appreciated that time T_r is not the time when the gas piston 182 is at the end of stroke, which can be either the physical end of stroke or the pre-defined end of stroke position. There may be a time lag between the reversal of the pumping direction and the actual end of stroke due to movement inertia. That is, a pump cycle does not completely overlap in time with the piston stroke cycle due to movement inertia as the piston may still move some distance in the original direction after the pumping direction has been reversed.

[0181] Thus, a control algorithm may be provided to predict when to reverse the pumping direction so that the gas piston 182 will be very close to the physical end of stroke at the actual end of each stroke but will not actually contact the gas chamber end walls during operation.

[0182] In an embodiment, T_r or LT may be determined as follows, as illustrated in FIG. 10B. For clarity, it is noted that FIG. 10B illustrates the pump cycle. As can be appreciated, pump unit 1174 is typically operated to apply the driving force on gas piston 182 cyclically in opposite directions, where the pump pressure is ramped up or down at the beginning and end of each pump cycle. An illustrative driving force profile over time (which may be similar to the pump control signal profile) is shown in FIG. 10B. It is noted

that the numbers in parentheses, e.g. “(1)”, “(2)”, “(3)”, etc., in FIG. 10B indicate the pump cycle number for identification purposes only.

[0183] Assuming pump Cycle 1 starts at time T_0 , when the hydraulic pump in pump unit 1174 starts to ramp up to a set pumping speed to provide a selected driving force or pressure (referred to as +P for ease of discussion) applied on gas piston 182, the gas piston 182 is driven by the driving force to move towards one end (e.g. the end on the right hand side in FIG. 10B) of the gas chamber in a first direction (e.g. the right direction).

[0184] In this regard, the pump output flow rate may be controlled based on a fixed input electrical signal. The pump may have an internal mechanism to provide the required flow rate precisely using internal mechanical feedback to self-compensate. This is helpful in a compression system where the load pressure may be constantly changing and a constant output flow rate is desirable.

[0185] Assuming gas piston 182 is initially at Position 1, or reaches Position 1 sometime after T_0 , gas piston 182 will leave Position 1 at some point in time, $T1(1)$, and this can be determined by controller 200' based on a signal received from proximity sensor 157b (such as when proximity sensor 157b turns off from an “on” state). Thus, proximity sensor 157b can be used to detect the time, $T1(1)$, at which time gas piston 182 leaves Position 1. As gas piston 182 continues to move right and reaches Position 2, at time $T2(1)$, proximity sensor 157a detects that gas piston 182 has reached Position 2 and sends a signal to controller 200' to indicate that gas piston 182 has reached Position 2 at time $T2(1)$. At this time, controller 200' receives, or may have received, signals from pressure sensor(s) 1104 and temperature sensor 1106 for determining a load pressure, $LP(1)$, applied on gas piston 182 at time $T2(1)$ and a fluid temperature of the hydraulic driving fluid, $FT(1)$.

[0186] At time $T2(1)$, or very shortly thereafter, controller 200' calculates, according to a pre-defined algorithm, as will be further discussed below, a lag time or the reversal time for the next pump cycle. The relationship between $LT(1)$ and $Tr(1)$ is $Tr(1)=T2(1)+LT(1)$. That is, once $LT(1)$ is determined, the pump reversal time $Tr(1)$ for reversing the pumping direction of the hydraulic pump and thus the direction of the hydraulic driving pressure (driving force) on gas piston 182 can be determined. The hydraulic pump may be operated to ramp down at a selected time interval before $Tr(1)$, as illustrated in FIG. 10B.

[0187] In a particular embodiment, the lag time LT for each pump cycle may be calculated based on three contribution factors, denoted as $f(V)$, $f(LP)$, and $f(FT)$ for ease of reference.

[0188] V is the average speed of gas piston 182 during a piston stroke, and can be calculated as $V=D/\Delta T$, where D is the distance travelled by gas piston 182 between times $T1$ and $T2$ and $\Delta T (=T2-T1)$ is the corresponding travel time. The lag time contribution $f(V)$ may be determined based on a pre-stored mapping table or a predetermined formula. The mapping table or formula may be based on empirical data, and may be updated during operation based on further data collected during operation. For example, the values in the mapping table may be initially set at values lower than the expected values for safety, such as by -50 milliseconds (ms), and be updated during operation so that each value in the mapping table is incremented by 1 ms in the required speed range until an end of stroke flag is detected. The values in the

mapping table may be subtracted by 25 ms every time a physical end of stroke has occurred. The mapping table may include different tables for different speed ranges so that closer mapping over each range can be achieved. In some embodiments, reduction of the values in the mapping tables may be limited to a maximum reduction of 250 ms below the expected or initial values.

[0189] As noted above, LP is the Load Pressure experienced by gas piston 182, and can be calculated as the pressure differential between the fluid pressures applied at the opposite ends of gas compressor 150', or the pressure difference between the fluid pressures in hydraulic fluid lines 1163a and 1163b. The lag time contribution $f(LP)$ may be determined based on an empirical formula, such as

$$f(LP)=a \times LP + b, \text{ or } f(LP)=a \times (b - LP),$$

where parameters “a” and “b” may be determined or selected based on empirical data obtained on the same or similar systems.

[0190] The lag time contribution factor $f(FT)$ may also be determined based on an empirical formula, such as

$$f(FT)=d \times FT + e, \text{ or } f(FT)=d \times (e - FT)$$

where parameters “d” and “e” may be determined or selected based on empirical data obtained on the same or similar systems.

[0191] In selected embodiments, the total lag time may be a simple sum of $f(V)$, $f(LP)$, and $f(FT)$, i.e., $LT=f(V)+f(LP)+f(FT)$. In other embodiments, the overall lag time may be a weighted sum or another function of the three contributing factors.

[0192] The lag time LT may be calculated in a suitable time unit that provides effective and adequate pump control. It has been found that for some applications, millisecond (ms) is a suitable time unit.

[0193] Assuming LT is calculated as a simple sum of the three contributing factors, the LT for pump Cycle 1 is:

$$LT(1)=f(V(1))+f(LP(1))+f(FT(1)).$$

[0194] $Tr(1)$ can then be determined as $Tr(1)=T2(1)+LT(1)$. Pump unit 1174 is controlled by controller 200' to reverse pumping direction at $Tr(1)$.

[0195] As can be appreciated, controller 200' may control the operation of pump unit 1174 in a number of different manners to achieve the same reversal timing. For example, instead of deterring the reversal timing directly, controller 200' may be configured to determine the time for commencing the ramp down, and adjust or calibrate this time. For a fixed ramp down interval (e.g. 300 ms), this would be equivalent to determining and adjusting the reversal timing. Further, the reversal time $Tr(1)$ may also be calculated from the ramp down start time if the ramp down interval is known.

[0196] In any event, at $Tr(1)$, pump Cycle 1 ends and the next cycle, pump Cycle 2 starts. In pump Cycle 2, pump unit 1174 is controlled by controller 200' to pump in the opposite direction as compared to Cycle 1 to drive gas piston in the second direction (e.g. in this example, the left direction as shown in FIG. 10A).

[0197] As the hydraulic pump ramps up in the opposite direction, to apply a driving force or pressure (-P) to drive gas piston towards the left direction, gas piston 182 will leave Position 2, which can be detected using proximity sensor 157a when it turns from the “on” state to the “off” state, and controller 200' can determine the time $T2(2)$ at which gas piston 182 leaves Position 2 based on the signal

received from proximity sensor 157a. When gas piston 182 returns to Position 1, proximity sensor 157b turns from off to on and produces and sends a signal to controller 200' to indicate that Position 1 is reached in Cycle 2 at time T1(2).

[0198] At time T1(2), controller 200' also receives, or may have received, signals from pressure sensor(s) 1104 and temperature sensor 1106 for determining a load pressure, LP(2) applied on gas piston 182 at time T1(2) and a fluid temperature of the hydraulic driving fluid, FT(2).

[0199] At time T1(2), or very shortly thereafter, controller 200' calculates a lag time for Cycle 2, LT(2), as: $LT(2)=f(V(2))+f(LP(2))+f(FT(2))$.

[0200] The next pump reversal time Tr(2) may be calculated $Tr(2)=T1(2)+LT(2)$.

[0201] Controller 200' then controls pump unit 1174 to reverse pumping direction for the next cycle at time Tr(2), or to pump in the current direction for a time interval of LT(2) before reversing the pumping direction.

[0202] At Tr(2), the next pump cycle, Cycle 3 starts. The process continues similar to Cycle 1.

[0203] It may be appreciated that, LT(1), LT(2), and lag times for other pump cycles, may or may not be the same. The lag times can be conveniently adjusted in real time to account for changes in environment and operating conditions.

[0204] To provide improved efficiency, each lag time may also be adjusted based on other factors or events. For example, when end of stroke indicators 1002a, 1002b are provided, the signals received from the end of stroke indicators 1002a, 1002b may be taken into account. For instance, for pump Cycle 1 in the example of FIG. 10B, if controller 200' has not received a signal from end of stroke indicator 1002a to indicate that gas piston 182 has reached the predefined end of stroke position after Cycle 2, which means that the calculated value for LT(1) was not long enough, then the initially calculated LT(3) value may be increased by a pre-selected increment, such as 1 ms. This value should be sufficiently small to avoid possible physical end of stroke.

[0205] In another example, if a calculated LT is too long, a physical end of stroke will occur, which may be detected by monitoring any spike in the detected load pressure LP. When a physical end of stroke is detected, which may be considered as an "end of stroke event", the initially calculated LT for a subsequent pump cycle may be reduced by a selected amount, such as 25 ms. This reduction time should be sufficiently large to avoid a possible further physical end of stroke. This reduction may be implemented by reducing the values in the mapping table for speed contribution by 25 ms per occurrence of an end of stroke event, up to a maximum of 250 ms. The maximum may be selected to prevent run away adjustment, particularly when the physical end of stroke events are due to some other reasons instead of over-determined lag time.

[0206] As now can be appreciated, the above control process can take into account of the changes in environment and operation conditions in real time, and provide efficient gas compression while reducing the risks of physical end of stroke.

[0207] A more realistic control signal (labelled as pump signal) profile applied to a pump for driving a gas compressor is shown in FIG. 17, with the corresponding pump pressure responses. The control signal is shown in the dash line, where the positive portions of the signal correspond to

pump signals applied for driving the gas piston in a first direction and the negative portions correspond to pump signals applied for driving the piston in the opposite, second direction. The solid lines in FIG. 17 represent the corresponding pump pressures at the respective output ports of the pump, which may be measured at lines 1163a and 1163b (P and S ports) respectively as illustrated in FIG. 10A. The thicker solid line corresponds to the pump pressure applied in the first direction, in response to the positive portions of the pump signal. The thinner solid line corresponds to the pump pressure applied in the second direction, in response to the negative portions of the pump signal.

[0208] The system shown in FIG. 10A is described in further details below.

[0209] In FIG. 10A, self-calibrating gas compressor system 126' may be modified from gas compressor system 126 illustrated in FIG. 7. Gas compressor 150' may be modified from gas compressor 150 illustrated in FIG. 2 and FIG. 3(i)-3(iv)). Generally, gas compressor system 126' adaptively controls the operation of gas compressor 150' to provide improved gas compression therein via controller 200'. Gas compressor system 126' may be a closed loop system as illustrated, or may be an open loop system as can be understood by those skilled in the art. In an embodiment, an open loop system (not shown) may use a pump unit similar to the pump unit 1174 combined with a 4-way valve to drive the reciprocal movement of the gas compressor piston, as can be understood by those skilled in the art. In some embodiments, the buffer chamber may be omitted. The piston stroke length for gas piston 182 can be controlled such that gas piston 182 driven by hydraulic fluid supply system 1160' and controller 200' can travel nearly the full length gas compression chamber in gas cylinder 180 with reduced risks of physical end of stroke.

[0210] As illustrated, gas compressor 150' is in hydraulic fluid communication with hydraulic fluid supply system 1160'. Controller 200' is in electronic communication with the illustrated sensors, either by wired communication or wireless communication. Hydraulic fluid supply system 1160' is controlled by controller 200'. In particular, controller 200' may be configured and programmed for controlling the operation of pump unit 1174. Pump unit 1174 can receive a control signal from controller 200' and adjust its pumping speed and pumping direction based on the control signal, to apply the driving fluid provided by reservoir 1172 to alternately drive hydraulic pistons 154a, 154b, and thus gas piston 182.

[0211] As discussed above, pump unit 1174 includes outlet ports S and P for selectively and alternately delivering a pressurized hydraulic fluid to each of fluid communication line 1163a or 1163b respectively. Pressure sensors 1004 may be electrically connected to each of the output ports S and P to provide sensed pressure signals to controller 200' for determining a load pressure applied to piston 182.

[0212] One or more temperature sensors 1006 may be electrically connected to at least one of hydraulic cylinders 152a or 152b for sensing a temperature of the driving fluid contained therein during movement of pistons 182, 154a, and 154b. Temperature sensor 1006 may be in electrical communication with controller 200' for providing a sensed temperature signal to the controller 200'.

[0213] Gas compressor system 126' can self-calibrate the operation of the pump unit to control the movement of piston 182 based on V, LP and FT, as described herein.

Stroke Movement of Piston

[0214] A “stroke” refers to the movement of a piston, such as piston **182**, within a gas compression chamber, such as chamber **181**, in each direction from the beginning to the end during the piston’s reciprocal linear movement in the chamber.

[0215] To achieve optimal gas compression, it is desirable for gas piston **182** to travel nearly the entire length between the end walls at ends **1008** and **1010**. However, to avoid possible physical end of stroke, piston **182** may be controlled to travel between pre-defined end of stroke positions which may be at a distance of 0.5" from the respective end wall at ends **1008** and **1010**.

[0216] In an embodiment, gas compressor **150'** is driven by a controlled hydraulic fluid supply system **1160'** and controller **200'** to provide smooth transition between strokes of gas piston **182** and efficient gas compression. Controller **200'** may be used to re-calibrate piston **182** displacement parameters to improve stroke efficiency during subsequent strokes based on data or signals indicative of the driving fluid temperature, piston speed, load pressure and stroke length information acquired during a prior stroke. As discussed herein, these signals can be derived from the pressure sensor **1004**, the temperature sensor **1006**, and proximity sensors **157a** and **157b**.

[0217] As noted above, sensors **1004**, **1006**, **157a** and **157b** may be electrically coupled to controller **200'** or wirelessly coupled (e.g. across a network).

[0218] Gas compressor system **126'** may generally operate in a similar manner as discussed with reference to gas compressor **126** of FIG. 7 but performs additional control actions and calculations as described above.

[0219] In an embodiment, controller **200'** of FIG. 10A may be further programmed to use additional sensor data obtained from gas compressor **150'** to improve stroke displacement of gas piston **182** during operation of gas compressor **150'**. Controller **200'** is configured for controlling driving fluid supply system **1160'** to provide smooth transitions between strokes while maximize or optimize gas compression efficiency.

[0220] For example, controller **200'** may be programmed in such a manner to control hydraulic fluid supply system **1160'** to ensure a smooth transition between strokes.

[0221] Further details of the operation of controller **200'** and pump unit **1174** are discussed below with reference to FIG. 13.

[0222] In some embodiments, proximity sensor **157a** is mounted on and extending within cylinder barrel **187a**. Proximity sensor **157a** is operable such that during operation of gas compressor **150'**, as piston **154a** is moving from left to right, just before piston **154a** reaches the position shown in FIG. 3(i), proximity sensor **157a** will detect the presence of a portion of the hydraulic piston **154a** within hydraulic cylinder **152a**. Proximity sensor **157b** may be similarly mounted cylinder barrel **187b** and used to detect the presence of another portion on piston **154b**. Based on such detections, the relative position of a piston face **182a**, **182b** (as shown in FIG. 10A) near an end of the cylinder (end **1008**, **1010**) can be derived.

[0223] End of stroke indicators **1002a**, **1002b** may be omitted in some embodiments, in which case piston positions detected by proximity sensors **157a**, **157b** may be used to indicate the pre-defined end of stroke positions.

[0224] Sensor **157a** may send a signal to controller **200'** indicating that the sensor **157a** is on, in response to which controller **200'** can take steps to change the operational mode of hydraulic fluid supply system **1160'**.

[0225] Proximity sensor **157b** may operate in a similar manner as described with reference to sensor **157a**.

[0226] Controller **200'** may be programmed to control hydraulic fluid supply system **1160** in such a manner as to provide for a relatively smooth slowing down, a stop, reversal in direction and speeding up of piston rod **194** along with hydraulic pistons **154a**, **154b** and gas piston **182** as piston rod **194**, hydraulic pistons **154a**, **154b** and gas piston **182** transition between a drive stroke to the right to a drive stroke to the left, and so on.

[0227] In some embodiments, proximity sensors **157a**, **157b** may be implemented using inductive proximity sensors, such as model BI 2-M12-Y1X-H1141 sensors manufactured by Turck, Inc. Inductive sensors are operable to generate proximity signals in response to a portion of piston rod **194** and/or hydraulic pistons **154a**, **154b** being proximate to the respective proximity sensors **157a** or **157b**. In an embodiment, the proximity sensors may be configured so that the sensor turns on when the sensor is in the proximity of a cut-out section of the piston rod so the sensor does not sense the presence of any piston material (e.g. steel) in its proximity, and turn off when an uncut section of the piston rod or an end of stroke indicator attached to the piston rod is within the proximity of the sensor so the sensor can sense the presence of the uncut section or the end of stroke indicator. The proximity threshold may be about 5 mm. That is, for example, if the end of indicator is within a 5 mm distance from the sensor, the sensor turns off. If there is no piston material (steel) within the 5 mm range, the sensor turns on.

[0228] Signals from proximity sensors **157a**, **157b** may be used to initiate capture of sensor measurements at other sensors, such as pressure and temperature sensors **1004**, **1006**.

[0229] Referring to FIGS. 11(a) to 11(e), an example operation of proximity sensors **157a** and **157b** is illustrated during displacement of hydraulic pistons **154a** and **154b** and gas piston **182** of gas compressor **150'** (shown in FIG. 10A). As shown, as hydraulic piston **154b** travels to the right in FIG. 11(a), proximity sensor **157b** turns on, as it is proximate to an end portion of hydraulic piston **154b**. This time, which may be recorded based on an internal clock in the controller, is considered as time **t1** and shown as **1301** in FIG. 13. The time **t1** is sent to controller **200'** for subsequent processing of the lag time. From the position shown in FIG. 11(a) to that shown in FIG. 11(b), proximity sensor **157b** may turn off as the portion of hydraulic piston **154b** travels away from sensor **157b** (see **1304** in FIG. 13). As pistons **154a** and **154b** continue to travel to the right from the position shown in FIG. 11(b) to FIG. 11(c), left proximity sensor **157a** turns on when a portion of hydraulic piston **154a** is located in a longitudinal position proximate to sensor **157a** (see **1306** in FIG. 13). This second time when the second sensor **157a** turns on is considered as **t2** and also provided to controller **200'** for calculating lag time measurements as described herein. For example, **t1** and **t2**, along with the distance between sensors **157a** and **157b** may be used to determine a speed of the piston **182**. Hydraulic pistons **154a**, **154b** and gas piston **182** continue to travel to the right as shown in FIGS. 11(d) and 11(e) until a desired

end of stroke is reached in FIG. 11(e) such that gas piston 182 is located proximal to an end of gas compression cylinder 180 (see FIG. 11(e)). Subsequent to FIG. 11(e), once the desired end of stroke is reached, both sensors 157a, and 157b turn off for a short period of time (shown as 1308 in FIG. 13).

[0230] Once the end of stroke is detected, the pump unit is operated at the same pumping rate or speed for the duration of the determined lag time before reversing the pumping direction (see 1308 in FIG. 13) to move hydraulic pistons 154a, 154b and gas piston 182 in an opposite direction (see 1314 in FIG. 13). The reversal of the pumping direction may include a deceleration phase in the same direction (e.g. from +X to 0 in 50 ms) and an acceleration phase in the opposite direction (e.g. from 0 to -X in 300 ms).

[0231] FIG. 15(a)-15(c) show schematic side views of gas compressor 150' during an example cycle of operation of hydraulic pistons 154a, 154b and gas piston 182. In FIG. 15(a), the right end of stroke of hydraulic piston 154b has been confirmed. As can be seen, gas piston 182 positioned within gas compression cylinder 180 has reached a pre-defined distance from a second end 1010 of the gas compression cylinder (e.g. $\frac{5}{8}$ "'). Subsequently, controller 200' generates a control signal to provide driving fluid to gas compressor 150' as discussed above to cause gas piston 182 to travel to the left. Once left proximity sensor 157a detects hydraulic piston 154a, proximity sensor 157a then turns on (see FIG. 15(b)). As pistons 182, 154a, and 154b travel to the left as shown in FIG. 15(c), right proximity sensor 157b then senses an end portion of hydraulic piston 154b and turns on. Controller 200' is configured to capture the time for left sensor 157a turning on in FIG. 15(b) as t1 and the time for right sensor 157b turning on in FIG. 15(c) as t2 such that the difference in time between t1 and t2 is used to calculate the speed of piston 182 as further discussed below.

[0232] FIG. 16 shows a schematic side view of the interior of the gas compressor 150'. As shown in FIG. 16, once gas piston 182 reaches a pre-defined desired distance (e.g. 0.5") shown at element 1602 from an end of gas compression cylinder 180, both proximity sensors 157a and 157b are turned off and piston rod 194 has stopped moving, this is considered as the end of a stroke in one direction such that piston rod 194 will start to move in an opposite direction for the next stroke.

[0233] As will be discussed below with respect to FIG. 10A and FIG. 14, proximity sensors 157a, 157b are used to indicate the times at which a particular part of gas piston 182 arrives at a position proximate the respective proximity sensor during a stroke and the sensed signal from proximity sensors 157a, 157b can be used to determine the (average) speed of the piston during a stroke and the time when piston 182 reached a predefined end position at or near the end of stroke. Additionally, as will be discussed with reference to FIG. 14, when proximity sensors 157a, 157b are triggered at different times, additional measurements may be taken (e.g. temperature and pressure signals may be detected and recorded) for adjusting the lag time values. The additional measurements are provided to controller 200' to modify the operation of hydraulic fluid supply system 1160' and thus gas compressor 150' for subsequent strokes to account for changes in temperature, and load pressure.

[0234] The following provides a description of the values captured by gas compressor 150' via end of stroke indicators 1002a, 1002b; proximity sensors 157a, 157b; pressure sen-

sor 1004 and temperature sensor 1006 (FIG. 10A) in order to calculate corresponding lag time values via controller 200' (FIG. 10A) and modify the operation of gas compressor 150' for subsequent strokes based on the overall lag time determined from the corresponding lag time values.

Lag Time Calculation

[0235] The total lag time calculation, as discussed herein, may be used to determine a time delay after an indicated end of stroke of a first hydraulic piston (e.g. 154b) in one direction (e.g. after both proximity sensors 157a, 157b have experienced a state transition before initiating a displacement signal from controller 200' to supply driving fluid to one of hydraulic fluid cylinders 152a, 152b such as to cause the transition of movement of a piston (e.g. piston 154a) in an opposite direction. A state transition of the sensor may be from OFF to ON or from ON to OFF. The ON or OFF information of each sensor may also be used by controller 200' to determine or process control signals. Examples of the time delay are shown at 1308 and 1318 in FIG. 13 such that after end of a stroke of the piston 182, once the previously determined lag time expires, pump 1174 signal is ramped in the reverse direction of the previous stroke. Ideally, it is desirable to start ramping up pump unit 1174 before gas piston 182 reaching the physical end of stroke.

[0236] For example, by using the lag time, controller 200' may cause hydraulic piston 154b to traverse past the respective proximity sensor 157b by a pre-defined distance in order to achieve a full stroke for the gas compressor 150', such that gas piston 182 is located proximal to one end of gas compression cylinder 180 (see FIG. 16).

[0237] As will be described below, controller 200' is programmed to calculate speed, pressure and temperature measurements (from sensed position information received from proximity sensors 157a, 157b, pressure sensor information from pressure sensor 1004 and temperature sensor information from temperature sensor 1006) from for gas compressor 150' in order to determine the lag time calibration parameters.

[0238] End of stroke indicators (1002a, 1002b) shown in FIG. 10A may also be communication with controller 200' to provide additional flags. For example, end of stroke indicators 1002a, 1002b provide signals indicating a piston end for hydraulic pistons 154a, 154b has reached a desired end of stroke position (e.g. a position located about half inch from the end of stroke of hydraulic piston 154a, 154b).

[0239] For example, if end of stroke indicators 1002a, 1002b indicate that a desired end of stroke has been reached in a previous stroke, then no adjustment is made to the lag time. Conversely, if a physical end of stroke is reached (e.g. such that a piston face 182a or 182b hits a respective end 1010 or 1008 of gas compression cylinder 180) then the overall lag time calibration is adjusted such that a second fixed pre-determined value (e.g. 25 ms) is deducted from the previously defined lag time value so that on the next stroke, hydraulic pistons 154a and 154b do not travel as far. Similarly, on a subsequent stroke if the end of stroke indicator indicates that it has not been activated (e.g. a desired end of stroke has not been reached), then the lag time is increased by the first pre-defined amount of time (e.g. 1 ms) until the end of stroke is reached. In this manner, controller 200' allows automated self-calibration of the lag time.

[0240] In at least some embodiments, proximity sensors **157a**, **157b** may be used to determine when a desired end of stroke for piston **182** has been reached such that end of stroke indicators **1002a** and **1002b** are not used.

[0241] In addition to the end of stroke indicators, speed, pressure and temperature measurements (as obtained from sensors **1004**, **1006** and based on proximity sensors **157a**, **157b**) are calculated and used to tailor the lag time at the end of each stroke to ensure that a full stroke is obtained for maximum gas compression of gas compressor **150'**.

Speed Measurements

[0242] Referring to FIGS. **10A**, **13** and **15(a)-15(c)**, to calculate speed, controller **200'** may be configured to capture a first time value for the start time (**1301**, FIG. **13**) that a first sensor **157a** is turned on (e.g. a negative transition, see FIG. **15(b)**) and then capture a second value for the time that second sensor **157b** (see FIG. **15(c)**) is turned on (see **1306**, FIG. **13**). The speed is calculated as the difference between the first and second time values divided by a fixed distance between first proximity sensor **157a** and second proximity sensor **157b** (e.g. 35" distance). This result provides the average speed for a particular stroke and is calculated by controller **200'**. The average speed is then mapped to predefined values for lag time associated with the speed (see FIG. **12**) and used to calculate a first lag time value based on the mapping (e.g. Lag (V)).

Hydraulic Pressure Measurements

[0243] Referring to FIG. **10A**, a hydraulic gas pressure transducer **1004** may be located on each of the P port and the S port of the pump unit **1174**. Each of gas pressure sensor/transducers **1004** may be in electronic communication with controller **200'** and provide a signal to controller **200'** for calculating the driving pressure (or load pressure) based on the pressure differential between the pressures at the P and S port (or in lines **1163a** and **1163b**) respectively. In response to receiving such signals, the controller **200'** calculates the hydraulic pressure difference as: Load Pressure=Absolute value of (Pressure P-Pressure S). The pressure values P and S are measured at the time that the second proximity sensor is turned on (e.g. sensor **157a** when piston **182** stroke is moving to the right). For example, the calculated pressure difference may provide an indication of the amount of work being performed by gas compressor system **100** with gas compressor **150'**. The absolute load pressure value is then used by controller **200'** to calculate a second lag time value (e.g. Lag(LP)) based on a previously determined relationship between pressure values and lag times for gas compressor **150'**. This second lag time value is then used by controller **200'** to modify the operation of gas compressor **150'** for subsequent strokes as discussed below in calculating the overall lag time value. Generally speaking, the higher the load pressure, the harder compressor **150'** is operating (e.g. hydraulic pistons **154a**, **154b** run slower). Thus, the higher the measured hydraulic pressure difference (between lines **1163a** and **1163b**), the higher the lag time value (e.g. Lag (LP)) associated with the pressure measurement in order to achieve a full stroke of hydraulic piston (e.g. **154a**, **154b**).

[0244] In alternative embodiments, it may not be necessary to measure the absolute pressure differential between the two ports P and S. For example, in a different embodi-

ment, the driving fluid may be provided with an open fluid circuit, and a directional valve may be used to alternately apply a positive pressure on one or the other of the two hydraulic pistons **154a** or **154b**. In this case, a single pressure sensor in the fluid supply line upstream of the directional valve may be sufficient to provide the pressure load measurement.

Driving Fluid Temperature Measurement

[0245] Gas compressor **150'** further comprises at least one temperature sensor **1006** (FIG. **10A**) for measuring the temperature of the hydraulic driving fluid contained therein (e.g. within chambers **152a**, **152b**) on a continuous basis. An example of a suitable temperature sensor may be Parker IQAN 20073658.

[0246] Generally speaking, based on prior experimental data, the hydraulic fluid temperature may typically range from 15° C. to 35° C. Therefore, in one embodiment, 35° C. may be used as a base reference point, where the lag adjustment is set at 0 ms. The output lag time associated with the temperature (e.g. the lag time contribution from the temperature value) may be -125 ms at 15° C. Lag times at other temperatures may be extrapolated based on linear relationship from these two points.

[0247] Without being limited to any particular theory, it is expected that when the driving fluid is cooler, its viscosity increases and provides more resistance to movement of hydraulic piston **182**. As a result, hydraulic piston **154a**, **154b** moves slower at lower temperatures. The lag time variable associated with the temperature is used to account for such change. Based on the sensed temperature (as provided by temperature sensor **1006**), a third lag time value (e.g. Lag(FT)) may be determined as described above. This third lag time value (e.g. Lag (FT)) is then used by controller **200'** to modify the operation of hydraulic fluid supply system **1160'** or hydraulic pump unit **1174** for supplying the driving fluid to drive subsequent strokes as discussed below in calculating the overall lag time value.

Total Lag Time (LT)

[0248] As noted above, during a stroke, the lag time values may be calculated for each of the first, second and third lag time values (associated respectively with the speed of the gas piston (V), the load pressure applied to the gas piston (LP), and the temperature of the driving fluid (FT)) and are then used to calculate an overall lag time value as discussed above and further illustrated below.

[0249] For example, when the gas piston **182** is in a stroke moving towards the right hand side as shown in FIG. **11(a)-11(e)**, the overall lag time provides a delay time between the time (T2) when the second proximity sensor **157a** is turned on (which indicates gas piston **182** has reached a predefined position, Position 2, in the stroke path) and the time to start ramping up hydraulic pump unit **1174** to apply a driving force in the opposite direction to drive gas piston **182** towards the left hand side. It is expected that after the lag time has elapsed, the speed of gas piston **182** will decelerate down to zero.

[0250] Conceptually, as shown in FIG. **13**, when travelling in one direction, after the second proximity sensor turns on (see **1306** in FIG. **13**), then both sensors turn off for a brief period of time (see **1308** in FIG. **13**). Hydraulic fluid supply system **1160'** is configured to delay for a period of time (lag

time) which is equivalent to $LT_V + LT_{FT} + LT_{LP}$, where, using the notations above, $LT_V = f(V)$, $LT_{FT} = f(FT)$, and $LT_{LP} = f(LP)$. As discussed above, LT_V may be determined based on the average speed of piston **182** during the previous stroke.

[0251] An example calculation of the lag time (LT) is provided below for illustration purposes.

Lag Time Contribution for Speed (V)

[0252] In this example, the average speed of piston **182**, which may be indicated by $V (=D/\Delta T)$ as discussed above, or by corresponding values of stroke per minute, is mapped to predetermined lag time values based empirical data and adjusted during operation, as illustrated in Table I.

[0253] Table I is an example mapping table for illustrating the relationship between the average stroke speed of gas piston **182** (e.g. in strokes per minute), the average speed (V) of gas piston **182** (in inch/ μ s), and the lag time contribution LT_V or $f(V)$ in ms. The data listed in Table I correspond to the data points shown in FIG. 12.

TABLE I

Strokes per minute	V (inch/ μ s)	LT_V (ms)
8.5	1500	255
8.0	1400	290
7.5	1300	330
7.0	1200	375
6.5	1115	425
6.0	1030	500
5.5	935	585
5.0	845	670
4.5	775	750
4.0	665	915
3.5	580	1060
3.0	495	1283
2.5	405	1600
2.0	325	2050
1.5	0	2050
1.0	0	2050

[0254] For the example in Table I, $D=35$ inches and ΔT is the time period between the triggering signals from the two proximity sensors in each stroke cycle. For each given V, the corresponding LT_V or $f(V)$ can be directly determined from Table I. A similar mapping table may be stored in a storage media accessible by controller **200'**. In some embodiments, during practical implementation, it may be desirable to maintain a minimum stroke speed, such as a minimum of 2 stroke/min (spm). For this reason, the mapping may be adjusted such that the lag time contribution $f(V)$ remains constant for piston speed below a certain threshold so that a minimum average speed of gas piston **182** is maintained, to result in 2 spm. In this case, there may be a wait time so that the net value of piston speed and wait time results in an overall lower speed for gas piston **182**, as illustrated in the last two rows (in bold) in Table I. For example, when $V=935$ in/ μ s (or 5.5 spm), LT_V is 595 ms from Table I.

Lag Time Contribution for Load Pressure (LP)

[0255] In this example, the lag time contribution associated with the load pressure $f(LP)$ may be calculated as:

$$f(LP) = a \times LP + b,$$

where $a=0.116959$, $b=-16.9591$, the unit for the lag time is millisecond (ms), and the unit for LP is psi. This formula

may be applied in a predefined pressure range, such as from 145 to 1000 psi, within which, the lag time contribution $f(LP)$ changes linearly from 0 ms to 100 ms. As an example, when the LP is 500 psi, the LT_{LP} from this equation is 42 ms.

Lag Time Contribution for Temperature (FT)

[0256] In this example, the lag time contribution associated with the fluid temperature $f(FT)$ may be calculated as:

$$f(FT) = d \times FT + e,$$

where $d=6.25$ and $e=-218.75$, FT is in $^{\circ}$ C., and the lag time is in ms. This formula may be applied in a predefined temperature range, such as from 15° C. to 35° C., with the lag time contribution changing from -125 ms to 0 ms. As an example, when the FT is 30° C., the LT_{FT} from this equation is -31 ms.

Total Lag time

[0257] In the above example, with $V=935$ in/ μ s (or 5.5 spm), $LP=500$ psi, and $FT=30^{\circ}$ C., the total lag time $LT=595+42-31=596$ ms.

End of Stroke Indicators

[0258] In one embodiment, each end of stroke indicator **1002a**, **1002b** may be located at one end of gas compressor **150'** and is configured to provide a signal to controller **200'** as to whether hydraulic piston **154a**, **154b** has travelled to a predefined distance to the terminal end wall of the respective cylinder, e.g. half an inch, which indicates a pre-defined end of stroke position. During operation, if a pre-defined end of stroke position (the desired full stroke) has not been reached, controller **200'** performs calibrations to adjust the mapping or algorithm for determining the speed contribution to the lag time in subsequent strokes of gas piston **182** such that the pre-defined end of stroke position is more likely to be reached in the next stroke. For example, an additional lag increment of 1 ms may be added to the next total lag time, and the lag time function for the piston speed may be adjusted so that future lag time calculation for the speed contribution will take this information into account. When the speed contribution is determined based on a mapping table, the values in the table may be adjusted.

[0259] Referring to FIGS. 10A and 14, a process for self-calibrating gas compressor **150'** to achieve full longitudinal strokes of gas piston **182** and hydraulic pistons **154a** and **154b** is shown at **1400**. The process **1400** begins at block **1402** when an operator causes gas compressor **150'** to start operation in response to receiving the start signal at an input. As shown at block **1404**, controller **200'** performs a startup process. In one embodiment, the startup process involves controller **200'** producing a displacement control signal which causes movement of the gas piston **182**, hydraulic pistons **154a** and **154b** in a first direction (e.g. to the right). As shown at **1406**, the time that an indication is received from a first proximity sensor (e.g. **157b**) that it has turned on is recorded as $t1$ (e.g. in response to sensing proximity of a portion of hydraulic piston **154b**) and the time that a second proximity sensor (e.g. **157a**) indicates that it has turned on is recorded as $t2$ (e.g. in response to sensing hydraulic piston **154a**). Times $t1$ and $t2$ are stored by controller **200'** (e.g. in a data store, not shown). At block **1410**, the speed of a stroke is calculated as discussed above based on $t1$ and $t2$ measurements and a fixed distance between the two sensors **157a** and **157b**. Additionally, at block **1410**, a measurement for pressure is captured by pressure sensor **1004** and pro-

vided to controller 200' in order to calculate the absolute pressure calculation noted above. Furthermore, at block 1410, a temperature measurement is captured by temperature sensor 1006 and provided to controller 200'. At block 1412, controller 200' then uses the calculated speed, load pressure and fluid temperature values to map to lag time values associated with each value (e.g. Lag (speed), Lag (pressure), and Lag(temperature)). At block 1414, the total lag time value is then calculated by controller 200' as the sum of the lag time values (e.g. Total lag time=Lag (speed)+Lag(pressure)+Lag(temperature)). At block 1416, controller 200' monitors the end of stroke indicators (e.g. 1002a, 1002b) to determine whether the end of stroke has been reached within a stroke. If yes, then at block 1418a, the total lag time remains the same. Further alternately (not illustrated), if a physical end of stroke is reached as determined by a pressure spike in the gas compressor 150', then controller 200' reduces the total lag time is by a first pre-defined value. If no end of stroke flag is detected at 1416, then at block 1418b, controller 200' increases the total lag time is by a second pre-defined value. At block 1420, controller 200' updates the total lag time based on the end of stroke indicator. At block 1422, controller 200' implements a delay time equivalent to the determined total lag time at block 1420. This delay is the amount of time it takes to maintain speed and then decelerate piston 182 stroke initiated at block 1404 to a speed of zero. Subsequent to the delay, controller 200' then proceeds to initiate the stroke (movement of hydraulic pistons 154a, 154b and gas piston 182) in the opposite direction at block 1424.

[0260] In one embodiment, the displacement control signal produced by controller 200' (FIG. 10A) for controlling the stroke of piston 182 and hydraulic pistons 154a, 154b of gas compressor 150' (FIG. 10A) is shown as waveform 1300 in FIG. 13. As shown on waveform 1300, controller 200' generates a first ramped portion 1302 in which the pump control signal is ramped from 0 to +X (pump speed) in 300 ms. As shown on waveform 1303, the movement of hydraulic piston 154b to the right causes right proximity sensor 157b to turn on.

[0261] At time 1304, the movement of piston 154b to the right causes right proximity sensor 157b to turn off and left proximity sensor 157a is triggered on by the movement of hydraulic piston 154a to the right at time 1306. At event 1304, a right START time (t1) value is saved.

[0262] At time 1306, a right STOP time (t2) value is saved. As noted above, the time values t1 and t2 are used by controller 200' to calculate the speed of piston 182 during movement to the right. Additionally, at time 1306, the hydraulic pressure is captured by pressure sensor 1004 and provided to controller 200'. Further, the temperature of hydraulic fluid flowing through gas compressor 150' is captured by temperature sensor 1006 and provided to controller 200' at time 1306. As discussed above, based on the speed, temperature, and pressure values, controller 200' calculates the total lag time. The total lag time calculated may be associated with movement of piston 182 to the right for use in modifying subsequent strokes to the right and stored within a data store for access by controller 200'.

[0263] At time 1308, both left and right proximity sensors 157a and 157b turn off for a very brief period of time and controller 200' recognizes that the end of stroke (e.g. for the movement of the hydraulic piston 154b) has been reached since both sensors are off. At time 1308, controller 200' waits

for a previously defined amount of lag time and once the right lag time has expired, the pump control signal causes hydraulic piston 154b to decelerate from X to zero, shown as the ramp down portion at 1310, in for example 50 ms. Thus, during this right stroke movement of hydraulic piston 154b, the lag time is calculated for the next stroke by controller 200'. If the end of stroke was not reached as determined by end of stroke indicator 1002a, then the lag time value is increased by a first pre-defined value. Conversely, the calculated lag time value is decreased by a second pre-defined value if the physical end of stroke is hit which is seen as a hydraulic pressure spike in gas compressor 150'. Controller 200' subsequently generates a negative displacement signal and accelerates hydraulic pistons 154a, 154b and gas piston 182 to the left such that the pump speed is ramped (accelerated) in the opposite direction from 0 to -X in 300 ms. Left proximity sensor 157a turns on with the movement and proximity of hydraulic piston 154a and at time 1316, right proximity sensor 157b turns on with the movement and proximity of hydraulic piston 154b. Also, at time 1316, speed of the left stroke is calculated along with pressure and temperature values respectively received from pressure sensor 1004 and temperature sensor 1006. At time 1318, both proximity sensors 157a and 157b are off and deceleration of the displacement control signal provided by controller 200' occurs after the previously defined lag time expires. It is noted that time portion 1312 indicates a short time period that both proximity sensors 157a and 157b are off and thus controller 200' determines that the end of stroke has been reached.

[0264] In a modified embodiment, when an end of stroke event, such as a physical end of stroke, has been detected during a stroke, instead of reducing the lag time (LT) by a large value (such as 25 ms) for the next stroke, the LT may be reduced by 1 ms (i.e., -1 ms) in each subsequent stroke until an end of stroke event is no longer detected. Such reduced decrease of LT after detection of end of stroke events may be used throughout the entire operation, or may be used during a selected period of operation. For example, when a physical end of stroke is expected to have occurred due to significant change in operation conditions or other external factors, a larger deduction in LT may be helpful. When an end of stroke event is expected to have occurred due to slight over-adjustment of the LT in the previous stroke, a smaller reduction in LT for the next stroke may provide a more smooth operation and quicker return to optimal operation. In further embodiments, an automatic reduction of 1 ms from the LT may also be implemented as long as the end of stroke position is reached during a previous stroke. If in the subsequent stroke, the end of stroke position is again reached, the LT is reduced further by 1 ms. However, if in the subsequent stroke, the end of stroke position is not reached, the LT may be then increased by 1 ms. In this manner, a more smooth operation may be achieved in at least some applications, and possible physical end of strokes due to slow drifting operating conditions may be avoided.

[0265] Various other variations to the foregoing are possible. By way of example only—instead of having two opposed hydraulic cylinders each being single acting but in opposite directions to provide a combined double acting hydraulic cylinder powered gas compressor:

[0266] a single but double acting hydraulic cylinder with two adjacent hydraulic fluid chambers may be provided with

a single buffer chamber located between the innermost hydraulic fluid chamber and the gas compression cylinder; [0267] a single, one way acting hydraulic cylinder with one hydraulic fluid chamber may be provided with a single buffer chamber located between the hydraulic fluid chamber and the gas compression cylinder, in which gas is only compressed in one gas compression chamber when the hydraulic piston of the hydraulic cylinder is moving on a drive stroke.

[0268] In various other variations a buffer chamber may be provided adjacent to a gas compression chamber but a driving fluid chamber may be not immediately adjacent to the buffer chamber; one or more other chambers may be interposed between the driving fluid chamber and the buffer chamber—but the buffer chamber still functions to inhibit movement of contaminants out of the gas compression chamber and in some embodiments may also protect a driving fluid chamber.

[0269] In other embodiments, more than one separate buffer chamber may be located in series to inhibit gas and contaminants migrating from the gas compression chamber.

[0270] One or more buffer chambers may also be used to ensure that a common piston rod through a gas compression chamber and hydraulic fluid chamber, which may contain adhered contamination from the gas compressor, is not transported into any hydraulic fluid chamber where the hydraulic oil may clean the rod. Accumulation of contamination over time into the hydraulic system is detrimental and thus employment of one or more buffer chambers may assist in reducing or substantially eliminating such accumulation.

[0271] When introducing elements of the present invention or the embodiments thereof, the articles “a,” “an,” “the,” and “said” are intended to mean that there are one or more of the elements. The terms “comprising,” “including,” and “having” are intended to be inclusive and mean that there may be additional elements other than the listed elements.

[0272] Of course, the above described embodiments are intended to be illustrative only and in no way limiting. The described embodiments of carrying out the invention are susceptible to many modifications of form, arrangement of parts, details, and order of operation. The invention, therefore, is intended to encompass all such modifications within its scope.

1.-30. (canceled)

31. A gas compressor system operable for use in an oil well producing system, said gas compressor system comprising:

- a driving fluid cylinder having a driving fluid chamber adapted for containing a driving fluid therein, and a driving fluid piston movable within said driving fluid chamber;
- a gas compression cylinder having a gas compression chamber adapted for holding a gas therein and a gas piston movable within said gas compression chamber and operable to compress a quantity of natural gas located within said gas compression chamber, said gas compression chamber being operable to be located proximate a well head of an oil well, said gas compressor system being operable for communication of a supply of natural gas from said oil well to said gas compression chamber;
- a buffer chamber located between said driving fluid chamber and said gas compression chamber;

said buffer chamber being operable to inhibit movement of at least one non-driving fluid component, when in operation, natural gas is located within said gas compression chamber and compressed by said gas piston, from said gas compression chamber into said driving fluid chamber.

32. (canceled)

33. A gas compressor system as claimed in claim 31 further comprising a piston rod that is fixedly connected to said driving fluid piston and said gas piston, such that in operation when said driving fluid flows into said driving fluid chamber said driving fluid piston drives said driving fluid piston such that said driving piston and said gas piston move together within said respective driving fluid chamber and said gas compression chamber.

34. A gas compressor as claimed in claim 33 wherein a volume of said driving fluid chamber and a volume of said buffer chamber overlap within said driving fluid cylinder, and wherein said piston rod extends from said driving fluid piston through said buffer chamber into said gas compression chamber to said gas piston.

35. (canceled)

36. (canceled)

37. A gas compressor as claimed in claim 34 wherein during operation, said buffer chamber varies in length dependent upon the position of said driving fluid piston in said driving fluid cylinder and the minimum length of said buffer chamber is greater than the stroke length of said gas piston, said piston rod and said hydraulic fluid piston.

38. A gas compressor as claimed in claim 34 wherein said buffer chamber is configured such that in operation, no portion of said piston rod that is received within said gas compression chamber will be received in a portion of said hydraulic cylinder that receives hydraulic fluid.

39. (canceled)

40. A gas compressor system as claimed in claim 31 wherein said at least one non-driving fluid component comprises a contaminant.

41.-42. (canceled)

43. A gas compressor system as claimed in claim 31 wherein said buffer chamber is located adjacent to said gas compression chamber on one side of said buffer chamber and said buffer chamber is located adjacent to said driving fluid chamber on an opposite side of said buffer chamber.

44. (canceled)

45. A gas compressor system as claimed in claim 44 wherein said driving fluid chamber and said buffer chamber are both located within said driving fluid cylinder.

46.-47. (canceled)

48. A gas compressor system as claimed in claim 31 further comprising a casing assembly located between said buffer chamber and said gas compression chamber and further comprising a seal device located at least partially within said casing, said seal device operable to inhibit natural gas and a non-gas component from migrating from said gas compression chamber into said buffer chamber.

49.-54. (canceled)

55. A gas compressor system as claimed in claim 31 wherein in operation, said buffer chamber is filled with an inert gas maintained at a pressure that exceeds the pressure at any time within the gas compression chamber.

56. (canceled)

57. A gas compressor system as claimed in claim 55 further comprising a gas pressure regulator system in communication with said buffer chamber, said gas pressure

regulator system operable to maintain the inert gas in said buffer chamber at a pressure that exceeds the pressure within the gas compression chamber during compression of the gas in the gas compression chamber.

58.-62. (canceled)

63. A gas compressor system as claimed in claim **31**, said system further comprising a driving fluid supply system operable to supply driving fluid to said driving fluid chamber to drive said driving fluid piston.

64. (canceled)

65. A gas compressor system as claimed in claim **63** wherein said driving fluid supply system is a closed loop system.

66. A gas compressor system as claimed in claim **63** further comprising a controller for controlling said driving fluid supply system for controlling the flow of driving fluid to said driving fluid chamber.

67. A gas compressor system as claimed in claim **66** further comprising:

a proximity sensor associated with said driving fluid cylinder, said proximity sensor operable to detect a position of said driving fluid piston within said driving fluid cylinder and send a signal to said controller;

said controller operable in response to receiving said signal received from said proximity sensor, and send a signal to said driving fluid supply system to control the flow of driving fluid into and out of said driving fluid chamber.

68. A gas compressor system as claimed in claim **31** further comprising a gas communication system operable to supply gas to said gas compression chamber and operable to remove gas compressed by said gas piston in gas compression chamber, from said gas compression chamber.

69. A gas compressor as claimed in claim **31** wherein: said driving fluid chamber is a first driving fluid cylinder having a first driving fluid chamber and a first driving fluid piston movable within said first driving chamber; said buffer chamber is a first buffer chamber located between a first driving fluid chamber and a first section of said gas compression chamber,

said gas compressor further comprises:

a second driving fluid cylinder having a second driving fluid chamber operable in use for containing a driving fluid and a second driving fluid piston movable within said second driving fluid chamber, and wherein said second driving fluid cylinder is located on an opposite side of said gas compression cylinder as said first driving fluid cylinder;

a second buffer chamber located between said second driving fluid chamber and a second section of said gas compression chamber, said second section of said gas compression chamber being on an opposite side of said gas piston to said first section of said gas compression chamber in said gas compression cylinder,

said first buffer chamber is adapted to inhibit movement of a gas located within said first gas compression chamber section into said first driving fluid chamber; and

said second buffer chamber is adapted to inhibit movement of a gas located within said second gas compression chamber section, from said second gas compression chamber section into said second driving fluid chamber.

70. A gas compressor system as claimed in claim **69** further comprising a driving fluid supply system operable to supply driving fluid to said first driving fluid chamber to drive said first driving fluid piston and operable to supply driving fluid to said second driving fluid chamber to drive said second driving fluid piston.

71.-72. (canceled)

73. A gas compressor system as claimed in claims **70** further comprising a controller for controlling said driving fluid supply system for controlling the flow of driving fluid to said first and second driving fluid chambers.

74. A gas compressor system as claimed in claim **69** wherein said piston rod that is fixedly connected to said first driving fluid piston, said gas piston and said second driving fluid piston, such that in operation when said driving fluid flows into said first driving fluid chamber said first driving fluid piston drives said first driving fluid piston such that said first driving fluid piston, said second driving fluid piston and said gas piston move together within said respective first driving fluid chamber, said second driving fluid chamber and said gas compression chamber, and such that in operation when said driving fluid flows into said second driving fluid chamber, said second driving fluid piston drives said second driving fluid piston such that said first driving fluid piston, said second driving fluid piston and said gas piston move together in an opposite direction within said respective first driving fluid chamber, said second driving fluid chamber and said gas compression chamber.

75. A gas compressor as claimed in claim **74** wherein a volume of said first driving fluid chamber and a volume of said first buffer chamber overlaps within said first driving fluid cylinder and a volume of said second driving fluid chamber and a volume of said second buffer chamber overlap within said second driving fluid cylinder and wherein said piston rod extends from said first driving fluid piston through said first buffer chamber into said gas compression chamber to said gas piston and extends further through said second buffer chamber to said second driving fluid piston.

76.-77. (canceled)

78. A gas compressor as claimed in claim **69** wherein during operation, said first buffer chamber varies in length dependent upon the position of said first driving fluid piston in said first driving fluid cylinder and the minimum length of said first buffer chamber is greater than the stroke length of said gas piston, said piston rod and said first and second hydraulic fluid pistons, and wherein during operation, said second buffer chamber varies in length dependent upon the position of said second driving fluid piston in said second driving fluid cylinder and the minimum length of said second buffer chamber is greater than the stroke length of said gas piston, said piston rod and said first and second hydraulic fluid pistons.

79. (canceled)

80. A gas compressor as claimed in claim **74** wherein said first buffer chamber is configured such that in operation, no portion of said piston rod that is received within said gas compression chamber will be received in a portion of said first hydraulic cylinder that receives hydraulic fluid and wherein said second buffer chamber is configured such that in operation, no portion of said piston rod that is received within said gas compression chamber will be received in a portion of said second hydraulic cylinder that receives hydraulic fluid.

81. A gas compressor as claimed in claim **69** wherein said first driving fluid piston is operable to drive said gas piston in an opposite direction to said second driving fluid piston.

82.-127. (canceled)

128. An oil well producing system comprising:

- a production tubing having a length extending along a well shaft that extends to an oil bearing formation;
- a passageway extending along at least the well shaft, said passageway operable to supply natural gas to a gas supply line, said gas supply line in communication with a gas compression chamber of a gas compressor system, said gas compressor system comprising any-of the gas compressor systems of claim **31**.

129.-130. (canceled)

131. An oil well producing system comprising a gas compressor, said gas compressor comprising:

- a driving fluid cylinder having a driving fluid chamber operable for containing a driving fluid therein and a driving fluid piston movable within said driving fluid chamber;
- a gas compression cylinder having a gas compression chamber operable for holding natural gas therein and a gas piston movable within said gas compression chamber and operable to compress a quantity of natural gas located within said gas compression chamber, said gas compression chamber being operable to be located proximate a well head of an oil well, said gas compression chamber being in communication with a supply of natural gas from said oil well;
- a buffer chamber located between said driving fluid chamber and said gas compression chamber, said buffer chamber containing a buffer gas component operable to substantially avoid contamination of said driving fluid in said driving fluid chamber, when natural gas is located within said gas compression chamber.

132. The gas compressor system of claim **31**, further comprising a control sub-system for adaptively controlling a hydraulic fluid supply to supply the driving fluid for applying a driving force on the driving fluid piston, the driving force being cyclically reversed between a first direction and

a second direction to cause the driving fluid piston to reciprocate in strokes, wherein the control sub-system comprises:

- first and second proximity sensors positioned and configured to respectively generate a first signal indicative of a first time (T1) when a first part of the driving fluid piston is in proximity of the first proximity sensor, and a second signal indicative of a second time (T2) when a second part of the driving fluid piston is in a proximity of the second proximity sensor, whereby a speed of the driving fluid piston during a first stroke of the driving fluid piston is calculable based on T1, T2 and a distance between the first and second proximity sensors;

one or more pressure sensors positioned and configured to generate a signal indicative of a load pressure applied on the driving fluid piston;

a temperature sensor positioned and configured to generate a signal indicative of a temperature of the driving fluid; and

a controller configured to receive signals from said sensors and for controlling the hydraulic fluid supply to control reversal of the driving force based on the speed of the driving fluid piston, the temperature of the driving fluid, and the load pressure applied to the driving fluid piston during the first stroke.

133. The gas compressor system of claim **132**, wherein the controller is configured to determine a lag time before reversing the direction of the driving force, and to delay reversal of the driving force by the lag time after T2.

134. The gas compressor system of claim **133**, further comprising an indicator positioned and configured for generating an end of stroke signal when the driving piston has reached a predefined end position in the first stroke, wherein the controller is configured to, in response to not receiving the end of stroke signal during the first stroke, increase the lag time by a pre-selected increment.

135. The gas compressor system of claim **133**, wherein the controller is configured to decrease the lag time when the temperature decreases to below a temperature threshold, and to increase the lag time when the load pressure increases.

* * * * *